

# FC-33 DC SELECTABLE INPUT ISOLATED SIGNAL CONDITIONER

## Product Guide

3505 HUTCHINSON ROAD  
CUMMING, GA 30040-5860

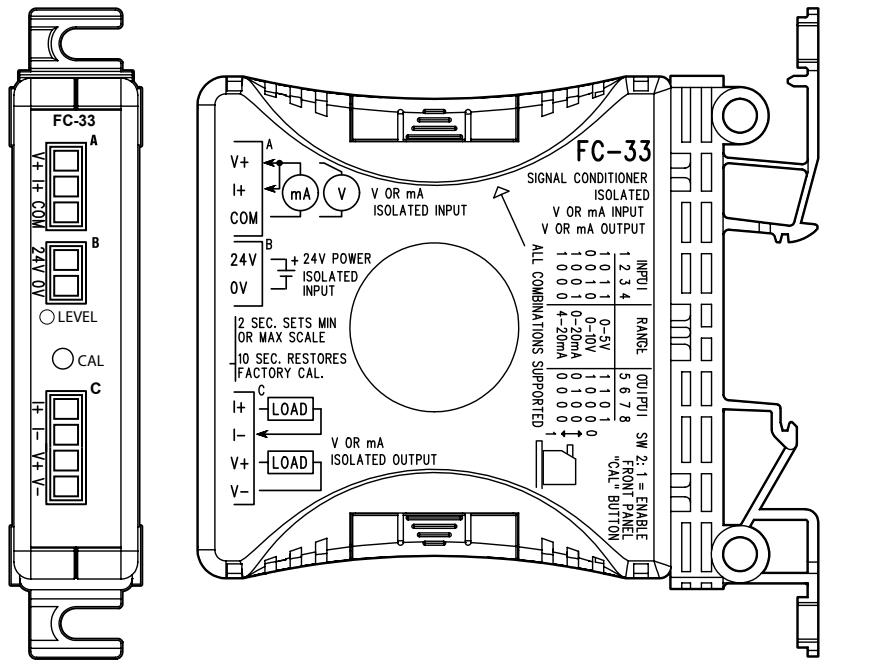

**Description:**  
The FC-33 is a DIN rail mount, selectable input / output signal conditioner with 1500VDC isolation between input and output and 1500VDC isolation from 24 volt power and input / output. The field configurable input/output types allow a wide ranging capability for 0 - 5V, 0 - 10V, 0 - 20mA, 4 - 20mA.

The FC-33 has user selectable factory-calibration, but also has OFFSET (zero) and SPAN (full scale) adjustments of the input signal. The OFFSET (zero) has an adjustment range of 0 to 25% of full scale input, the SPAN (full scale) has an adjustment of 80 to 102%.

**Application**  
The FC-33 field configurable isolated input/output signal conditioner is useful in eliminating ground loops and interfacing sensors to our PLC analog input modules. The FC-33 has 3 way isolation, this feature solves many types of configuration problems. For example, the signal conditioner can be configured for sinking input and sourcing output. It also allows signal translation from current input to voltage output or voltage input to current output.

This feature would be useful when you have limited type and number of channels in your system design, i.e. 8 channels of 4-20mA, 7 which are used and one transmitter that is 0 - 10V.

**LEVEL LED**  
This LED is a powerful tool when setting up the signal conditioner. During normal operation the LED will blink at a proportional rate to the selected input signal level. When performing field calibration the LED is used for indication of the internal calibration process.

**CAL - Pushbutton**  
This pushbutton along with various switch settings, allows you to calibrate the signal conditioner for your application or restore factory default calibration.

### Input Selection

The signal conditioner can be configured for either DC milliamps or DC volts. Input and Output signal types are 0 - 5V, 0 - 10V, 0 - 20mA, 4 - 20mA.

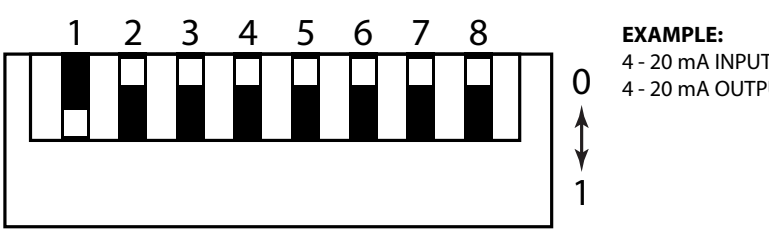

Input Ranges	Output Ranges	Switch Position							
		1	2	3	4	5	6	7	8
0 - 5V		1	0	1	1				
0 - 10V		0	0	1	0				
0 - 20mA		1	0	0	1				
*4 - 20mA		1	0	0	0				
	0 - 5V					1	1	0	1
	0 - 10V					1	0	0	0
	0 - 20mA					0	1	0	0
	4 - 20mA					0	0	0	0
<b>Factory Default Settings</b>									
4 - 20mA	4 - 20mA	1	0	0	0	0	0	0	0

\* Must connect jumper from V+ to I+ for current input

### Specifications

<b>Input Ranges</b>	0-5V, 0-10V, 0-20mA, 4-20mA
<b>Input Impedance</b>	250Ω ±0.1% current input 200KΩ / 400KΩ Voltage Input
<b>Output Ranges</b>	0-5V, 0-10V, 0-20mA, 4-20mA
<b>Load Impedance</b>	2KΩ minimum, voltage output 0Ω minimum, current output
<b>Maximum Load / Current</b>	550Ω @ 24V sink/source
<b>Sample Duration Time</b>	10mS
<b>Filter Characteristic</b>	-3dB @ 3Hz, -6dB/octave
<b>Linearity Error</b>	0.05% FSO maximum
<b>Stability</b>	0.05% FSO Maximum

NOTE: All data 0-60°C except where specified.  
\*Internal Analog convertor resolution is 12-bit

**CAUTION: PRODUCT MAY BE DAMAGED IF CURRENT OUTPUT (I+/I-) AND VOLTAGE OUTPUT (V+/V-) ARE BOTH CONNECTED TO LOADS. DO NOT TIE THE I+ TERMINAL TO THE V- TERMINAL.**

### Adjustments

The FC-33 has built-in self-calibration, but also has OFFSET (zero) and SPAN (full scale) adjustments of the input signal. If your application requires, different span or offset (i.e. 3.6mA offset and 19.6mA span) you can adjust accordingly.

#### Application Adjustments

##### Calibrating the Input Signal Level -

- 1 Select the signal range (i.e. 4 - 20mA).
- 2 Connect 24 volt power to the signal conditioner.
- 3 Connect the minimum input signal level.
- 4 Turn Switch 2 ON, press and hold the CAL pushbutton until the LEVEL LED comes ON steady (approx. 3 seconds), then release immediately. If the pushbutton is NOT released while the Level LED is ON steady, the signal conditioner will return to factory calibration.
- 5 Repeat above sequence for maximum input signal.
- 6 Turn Switch 2 OFF.

##### To return to factory calibration-

- 1 Turn switch 2 ON, press and hold the CAL pushbutton until the LEVEL LED comes ON steady and then starts flashing (approx. 10 seconds), then release the pushbutton. The unit has now been returned to factory calibration.
- 2 Turn Switch 2 OFF.

### General Specifications

<b>Accuracy vs. Temperature</b>	± 0.005% / °C (50 ppm / °C)
<b>Input Power</b>	24VDC ± 10% @ 50mA
<b>Recommended Fuse</b>	0.032A Littelfuse Series 217 Current Inputs
<b>Isolation</b>	1500VDC input - output 1500VDC power - input 1500VDC power - output * applied for 1 second
<b>Maximum Inaccuracy of Output (Includes Offset, Span, Linearity)</b>	0.05% FSO @ 25°C 0.25% FSO @ 0 - 60°C
<b>Output Current</b>	21mA Maximum (for mA output)
<b>Approximate Field Calibration Range</b>	0 - 25% (0 - 1.5V / 5V Mode) 80 - 102% (4 - 5.1V / 5V Mode)

### Operating Specifications

<b>Operating Temperature</b>	0 to 60°C (32 to 140°F)
<b>Storage Temperature</b>	-20 to 70°C (-4 to 158°F)
<b>Relative Humidity</b>	5 to 90% (non-condensing)
<b>Environmental Air</b>	No Corrosive Gases Permitted
<b>Vibration</b>	MIL STD 810C 514.2
<b>Shock</b>	MIL STD 810C 516.2
<b>Noise Immunity</b>	NEMA ICS3-304

### Typical Connections

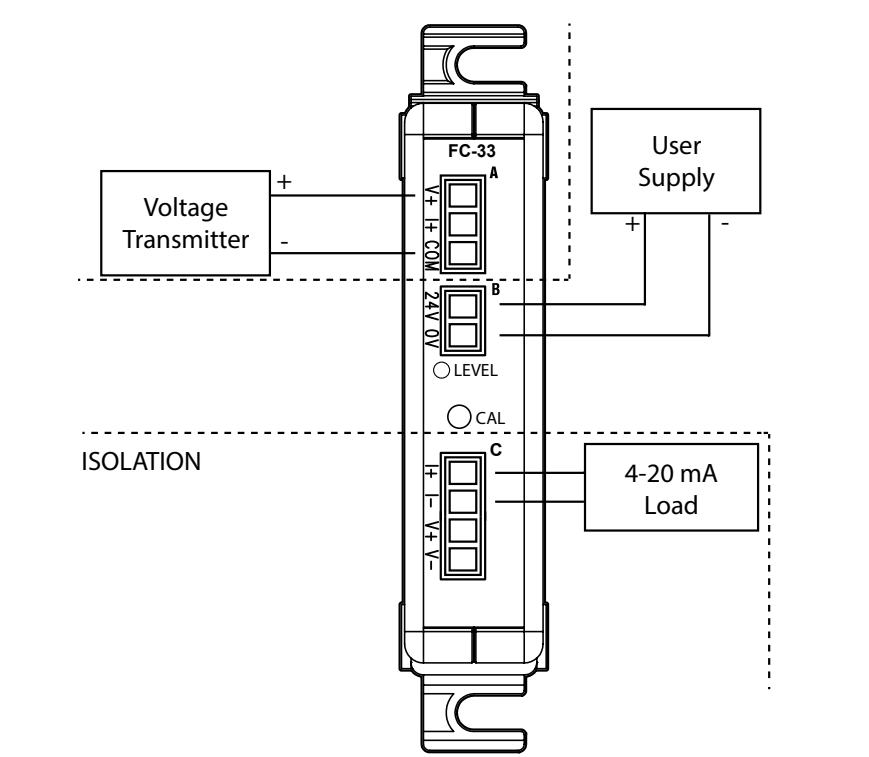

Voltage Input and Current Output

Theoretical Step Response			
% of Full Scale Step	60%	90%	95%
FC-33 0-5V Input	63ms	132ms	172ms
FC-33 4-20mA Input	63ms	132ms	172ms
FC-33 0-10V Input	91ms	191ms	249ms

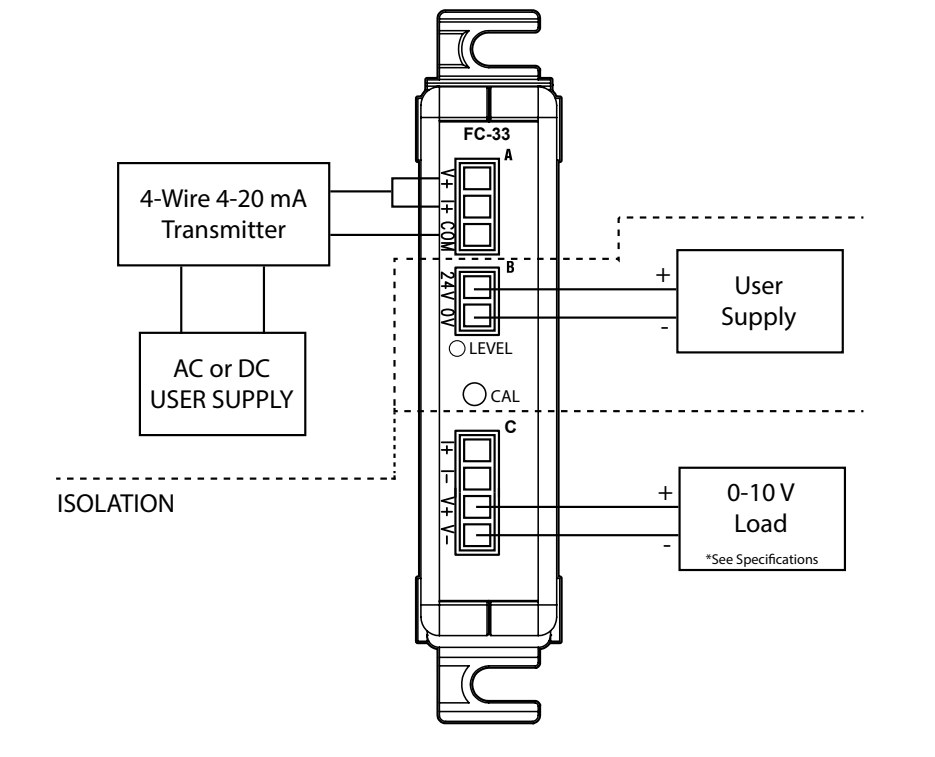

4-20mA Input to Isolated 0-10V Sinking Output

### UL Information

USL: ANSI/ISA 12.12.01-2012 file E200031, USA  
CNL: CSA22.2 No. 213 file E200031, Canada  
CE EN61131-2

This equipment is suitable for use in Class 1, Division 2, Groups A, B, C and D or non-hazardous locations only.

A. THIS EQUIPMENT IS SUITABLE FOR USE IN CLASS 1, DIVISION 2, GROUPS A, B, C AND D OR NON-HAZARDOUS LOCATIONS ONLY.

Cet équipement est conçu pour être utilisé dans des environnements de Classe 1, Division 2, Groupes A, B, C, D ou non dangereux.

B. WARNING - EXPLOSION HAZARD - SUBSTITUTION OF COMPONENTS MAY INPAIR SUITABILITY FOR CLASS 1, DIVISION 2/ZONE 2.

AVERTISSEMENT : Risque d'explosion: la substitution de composants peut compromettre la convenance pour la Classe 1, Division 2/Zone 2.

C. WARNING - EXPLOSION HAZARD - DO NOT DISCONNECT EQUIPMENT UNLESS POWER HAS BEEN SWITCHED OFF OR THE AREA IS KNOWN TO BE NON-HAZARDOUS.

AVERTISSEMENT: Risque d'explosion: Ne pas déconnecter l'équipement à moins que l'alimentation ne soit coupée ou que la zone ne soit reconnue non dangereuse.