

# SNAP Analog Input Modules

## Features

- Resolution = 0.004% of nominal range
- Two, 4, 8, or 32 single-ended inputs per module
- Out-of-range indication
- Factory calibrated; no user adjustment necessary



SNAP Analog Input Modules

## Description

SNAP I/O analog input modules are part of Opto 22's SNAP PAC System. All of these modules mount on a SNAP PAC rack with a SNAP PAC brain or R-series controller, either a standard wired model or a Wired+Wireless™ model.

A minimum number of SNAP module types support a full range of analog input requirements. These software-configurable modules handle a wide variety of signal levels. They provide high resolution (0.004% of nominal range) for precise signal levels, as well as multiple-channel packaging. All SNAP analog modules are factory calibrated and individually tested. Part numbers ending in -FM are Factory Mutual approved.

SNAP analog input modules have an on-board microprocessor to provide module-level intelligence, which makes them an ideal choice for Original Equipment Manufacturers (OEMs). For additional information about the standalone operation of SNAP analog modules, see Opto 22 form #0876, *SNAP I/O Module Integration Guide*.

**Notes for legacy hardware:** Some of these modules also work with older Opto 22 I/O processors (brains or on-the-rack controllers) and M-series or B-series racks. To check processor compatibility, see the table on [page 3](#).

Specifications begin on [page 4](#). For dimensional drawings, see pages [38–49](#).

**IMPORTANT:** Any system using analog sensors and input modules should be calibrated annually for analog signals. For I/O units on a SNAP PAC System, use the PAC Control™ commands "Calculate and Set Offset" and "Calculate and Set Gain." For other Ethernet-based I/O units, you can also

## Part Number

Part	Description	See page
SNAP-AIARMS	2-channel 0 to 10 amp RMS AC/DC input	4
SNAP-AIMA	2-channel analog current input, -20 to +20 mA	6
SNAP-AIMA-4	4-channel analog current input -20 to +20 mA	6
SNAP-AIMA-8	8-channel analog current input -20 to +20 mA	8
SNAP-AIMA-32 SNAP-AIMA-32-FM*	32-channel analog current input -20 to +20 mA	9
SNAP-AIRATE	2-channel 0–25,000 Hz analog rate input	11
SNAP-AIR40K-4	4-channel analog resistor/thermistor input, 40 K Ohms, 20 K Ohms, 10 K Ohms, or 5 K Ohms	13
SNAP-AIR400K-8	8-channel analog resistor/thermistor input, 400 K Ohms	14
SNAP-AIRTD	2-channel 100 ohm platinum RTD input	18
SNAP-AIRTD-1K	2-channel 1000 ohm platinum RTD input	18
SNAP-AIRTD-10	2-channel 10 ohm copper RTD input	18
SNAP-AIRTD-8U	8-channel multifunction RTD/resistance input	20
SNAP-AICTD	2-channel analog temperature input, ICTD	23
SNAP-AICTD-4	4-channel analog temperature input, ICTD	23
SNAP-AICTD-8	8-channel analog temperature input, ICTD	25
SNAP-AITM	2-channel analog type E, J, or K thermocouple or -150 to +150 mV input or -75 to +75 mV input	26
SNAP-AITM-2	2-channel analog type B, C, D, G, N, T, R, or S thermocouple or -50 to +50 mV DC or -25 to +25 mV DC input	27
SNAP-AITM-8 SNAP-AITM-8-FM*	8-channel B, C, D, E, G, J, K, N, R, S, or T thermocouple or -75 to +75 mV, -50 to +50 mV, or -25 to +25 mV input	28
SNAP-AIVRMS	2-channel 0 to 250 V RMS AC/DC input	29
SNAP-AIV	2-channel analog voltage input -10 to +10 VDC or -5 to +5 VDC	30
SNAP-AIV-4	4-channel analog voltage input -10 to +10 VDC or -5 to +5 VDC	30
SNAP-AIV-8	8-channel analog voltage input -10 to +10 VDC or -5 to +5 VDC	32
SNAP-AIV-32 SNAP-AIV-32-FM*	32-channel analog voltage input -10 to +10 VDC or -5 to +5 VDC	33
SNAP-AIMV2-4	4-channel -50 to +50 mV input or -25 to +25 mV input	35
SNAP-AIMV-4	4-channel -150 to +150 mV input or -75 to +75 mV input	36

\* Factory Mutual approved

use PAC Manager™ software to calculate and set offset and gain.

### Isolation

All SNAP analog input modules are isolated from all other modules and from the SNAP I/O processor. The modules in this data sheet do not have channel-to-channel isolation, however. (If you need isolated analog modules, see Opto 22 form #1182.)

Transformer isolation prevents ground loop currents from flowing between field devices and causing noise that produces erroneous readings. Ground loop currents are caused when two grounded field devices share a connection, and the ground potential at each device is different.

Isolation also protects sensitive control electronics from industrial field signals.

**IMPORTANT:** Since these analog input modules provide multiple single-ended input channels with a common reference, the channels are not isolated from each other. (See Opto 22 form #1182 for isolated modules.)

### Bipolar and Unipolar Input Modules

Most SNAP analog input modules are considered to be bipolar, which means the range extends equal amounts above

## SNAP Analog Input Modules

and below zero. An example of this is the SNAP-AIV module, which has a range of -10 to +10 VDC.

Some modules are considered unipolar, which means the range starts or ends at zero. For example, the SNAP-AIVRMS module has a range of 0 to 250 VAC because AC current cannot be negative.

### Nominal Range and Over-range Limits

All SNAP analog input modules have a nominal range for the field signal and most support a 10% over-range limit. The nominal range is the normal range of the field signal for the module or point configuration. The over-range limit is the maximum valid field signal the module or point configuration can read outside of the nominal range. For example, the over-range limits for the SNAP-AIV are -11 and +11 VDC, and for the SNAP-AIVRMS, the over-range limit is 275 VAC.

Some modules or point configurations do not support field signals outside of the nominal range. For example, points configured as temperature inputs (thermocouple, RTD, ICTD) do not support over-range readings.

When the field signal is outside of the over-range limits of the module, the brain will not be able to determine if the value is too high or too low, so it will return an "out of range" value of -32768.0

Over-range limits only apply to input modules. Output modules are limited to their nominal ranges.

# SNAP Analog Input Modules

## Installation

Note module and processor compatibility in the following table:

Modules	Compatible I/O Processors
32-channel inputs 8-channel inputs SNAP-AIRTD-10 SNAP-AIRTD-1K	SNAP PAC R-series controllers and SNAP PAC brains, including Wired+Wireless models
4-channel inputs	SNAP PAC R-series controllers and SNAP PAC brains, including Wired+Wireless models Also the following legacy brains: SNAP Ethernet, SNAP Simple, SNAP Ultimate; SNAP-DNP-ASDS; SNAP OEM
2-channel inputs (except SNAP-AIRTD-10 and SNAP-AIRTD-1K)	SNAP PAC R-series controllers and SNAP PAC brains, including Wired+Wireless models Also the following legacy brains: SNAP Ethernet, SNAP Simple, SNAP Ultimate; SNAP-DNP-ASDS; SNAP OEM; serial SNAP brains (B3000, Modbus, Profibus); B3000-HA; B6

All modules can be used with SNAP PAC racks and can be placed in any position on the rack. Two- and four-channel modules (except the SNAP-AIRTD-10 and SNAP-AIRTD-1K) can also be used with legacy SNAP M-series and B-series mounting racks. (For more information on using legacy hardware, see form #1688, the *SNAP PAC System Migration Technical Note*.)

Modules snap securely into place in the row of connectors on the mounting rack. Each module connector has a number. Analog input modules and other types of SNAP I/O modules are mounted on the module connectors starting at module position zero.

Modules require a special tool (provided) for removal.

The following diagram shows part of a SNAP PAC mounting rack.

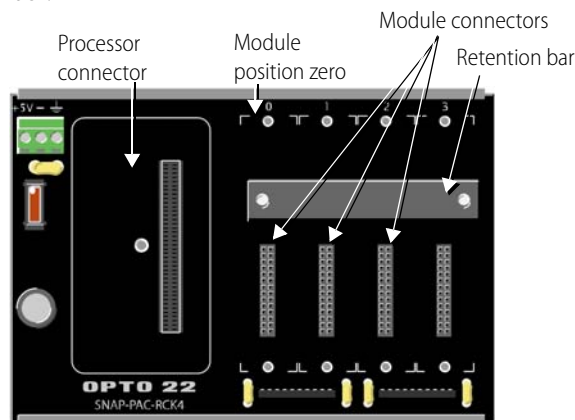

1. Place the rack so that the module connector numbers are right-side up, with zero on the left, as shown in the diagram above. (If your rack has screw connectors, the screw connectors will be at the bottom.)
2. Position the module over the module connector, aligning the small slot at the base of the module with the retention bar on the rack. When positioning modules next to each other, be sure to align the male and female module keys at the tops of the modules before snapping a module into position.
3. With the module correctly aligned, push on the module to snap it into place.
4. (Optional) Use standard 4-40 x 1/4 truss-head Phillips hold-down screws to secure both sides of each module.  
**CAUTION:** Do not over-tighten screws.
5. Follow the wiring diagrams beginning on [page 4](#) to attach modules to the devices they monitor. Most modules accept 22 to 14 AWG wire; the SNAP-AITM-8 accepts a maximum of two solid 18 AWG wires.

**For faster, easier field wiring** installation and maintenance, use **SNAP TEX** cables and breakout boards. See Opto 22 form #1756, the *SNAP TEX Cables & Breakout Boards Data Sheet*, for compatibility and specifications.

## 0 to 10 Amp RMS AC/DC Input Module

### Description

The SNAP-AIARMS module provides an input range of 0 to 10 amps RMS AC/DC. An ideal input is the 5-amp secondary of a standard current transformer used to monitor AC line current.

The SNAP-AIARMS module may be used to monitor AC current to greater than a 100-amp range, using a current transformer of suitable ratio.

If you need a module with channel-to-channel isolation, see form #1182, the *SNAP Isolated Analog Input Modules Data Sheet*.

**Wiring diagrams** are on the following page.



## SNAP Analog Input Modules

Part Number	Description
SNAP-AIARMS	Two-channel 0 to 10 amp RMS AC/DC input

### Specifications

Input Range	0 to 10 amp RMS AC/DC
Input Over-Range	To 11 amps
Input Resistance	0.005 ohms
Maximum Input	11 amps AC/DC
Accuracy (AC)	±8 mA and ±0.2% reading
Resolution	400 microamps
DC Reversal	±16 mA (0.16%)
Input Response Time (Step Change)	63.2% (158 V) in 50 mS 99% (248 V) in 75 mS
Data Freshness (Max)	32.3 ms
DC Common Mode Rejection	>-120 dB
AC Common Mode Rejection	>-120 dB at 60 Hz
Maximum Operating Common Mode Voltage	250 V
Isolation	1500 V
Power Requirements	5 VDC (±0.15 V) at 170 mA
Operating Temperature	-20 °C to 70 °C
Storage Temperature	-40 °C to 85 °C
Wire size	22 to 14 AWG
Torque, hold-down screws	4 in-lb (0.45 N-m)
Torque, connector screws	5.26 in-lb (0.6 N-m)
Agency Approvals	UL, FM, CE, RoHS, DFARS
Warranty	Lifetime

# SNAP Analog Input Modules

## 0 to 10 Amp RMS AC/DC Input Module (continued)

### SNAP-AIARMS Wiring Diagrams

Two possible wiring diagrams are shown below.

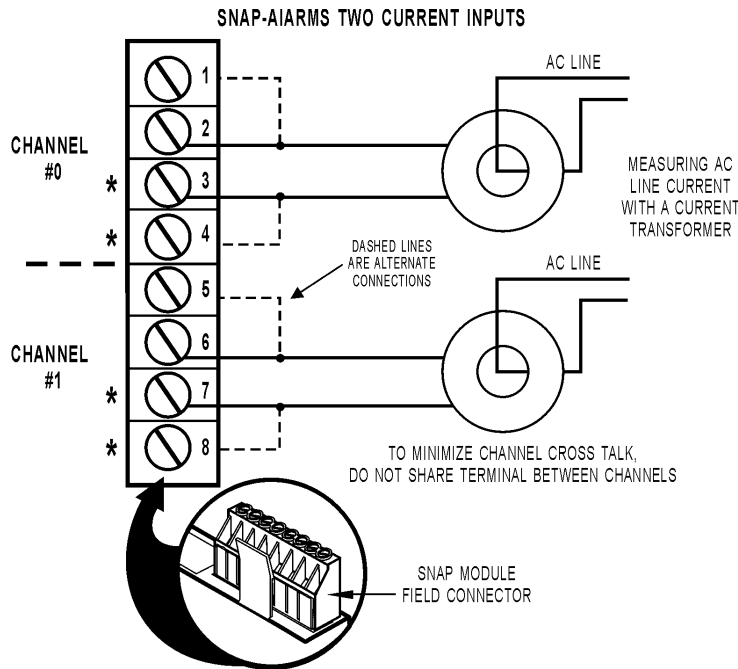

\* Terminals 3, 4, 7, and 8 share a common connection inside the module. **Make sure you observe polarity** when connecting the second channel. To avoid a potentially hazardous short, double-check wiring before turning on the current to be monitored.

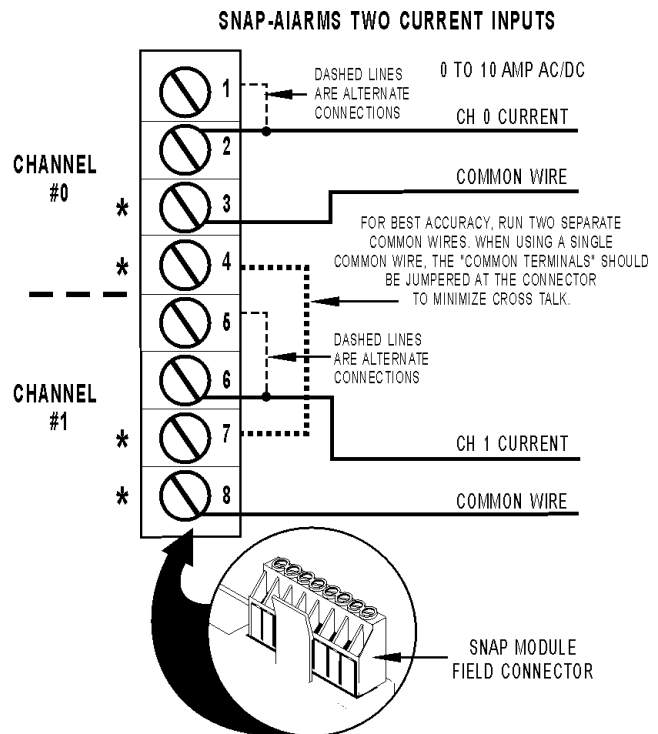
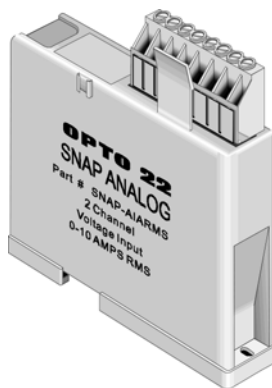

# SNAP Analog Input Modules

## Current Input Module, -20 mA to +20 mA, Two or Four Channels

### Specifications

Input Range	-20 mA to +20 mA
Resolution	0.8 microamps
Over-Range Limits	From -22 to +22 mA (+/-20 mA range)
Input Response Time (% of span/ delta I/delta tme)	99.9% / 19.9 mA / 10 ms
Data Freshness (Max)	SNAP-AIMA: 11.5 ms SNAP-AIMA-4: 23 ms
DC Common Mode Rejection	>-120 dB
AC Common Mode Rejection	>-120 dB @ 60 Hz
Maximum Survivable Input	36 mA or 9 VDC
Maximum Operating Common Mode Voltage	250 V
Accuracy	0.05% (10 microamps)
DRIFT: Gain Temperature Coefficient	30 PPM/ °C
DRIFT: Offset Temperature Coefficient	15 PPM/ °C
Power Requirements	5 VDC (±0.15 ) @ 170 mA
Input Resistance - Single Ended	200 ohms (each channel)
Operating Temperature	-20 °C to 70 °C
Storage Temperature	-40 °C to 85 °C
Torque, hold-down screws	4 in-lb (0.45 N-m)
Torque, connector screws	5.26 in-lb (0.6 N-m)
Wire size	22 to 14 AWG
Agency Approvals	UL, FM, CE, RoHS, DFARS ATEX (SNAP-AIMA-4 only)
Warranty	Lifetime

Part Number	Description
SNAP-AIMA	Two-channel analog current input, -20 mA to +20 mA
SNAP-AIMA-4	Four-channel analog current input, -20 mA to +20 mA

### Description

The SNAP-AIMA and SNAP-AIMA-4 modules provide an input range of -20mA to +20mA. The SNAP-AIMA has two channels, and the SNAP-AIMA-4 has four. If you need a similar module with more channels, see [page 9](#). Check the table on [page 3](#) for I/O processor compatibility. These modules DO NOT supply loop excitation current.

Since all inputs share a common reference, the module must be installed at the beginning or end of a typical 4–20mA loop. If you are using both standard and self-sourcing transmitters, either put the transmitters on different power supplies, or use different power supplies. If you need channels that are isolated from each other on the same module, see Opto 22 form #1182.



### SNAP-AIMA Wiring (Two channels)

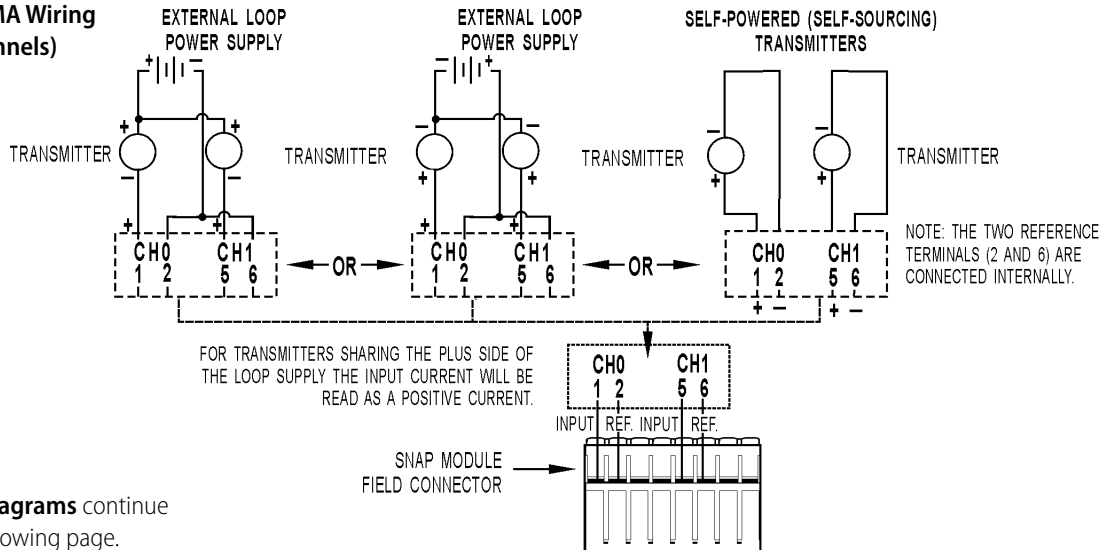

Wiring diagrams continue on the following page.



# SNAP Analog Input Modules

## Current Input Module, -20 mA to +20 mA, Two or Four Channels (continued)

### SNAP-AIMA-4 Wiring (Four channels)

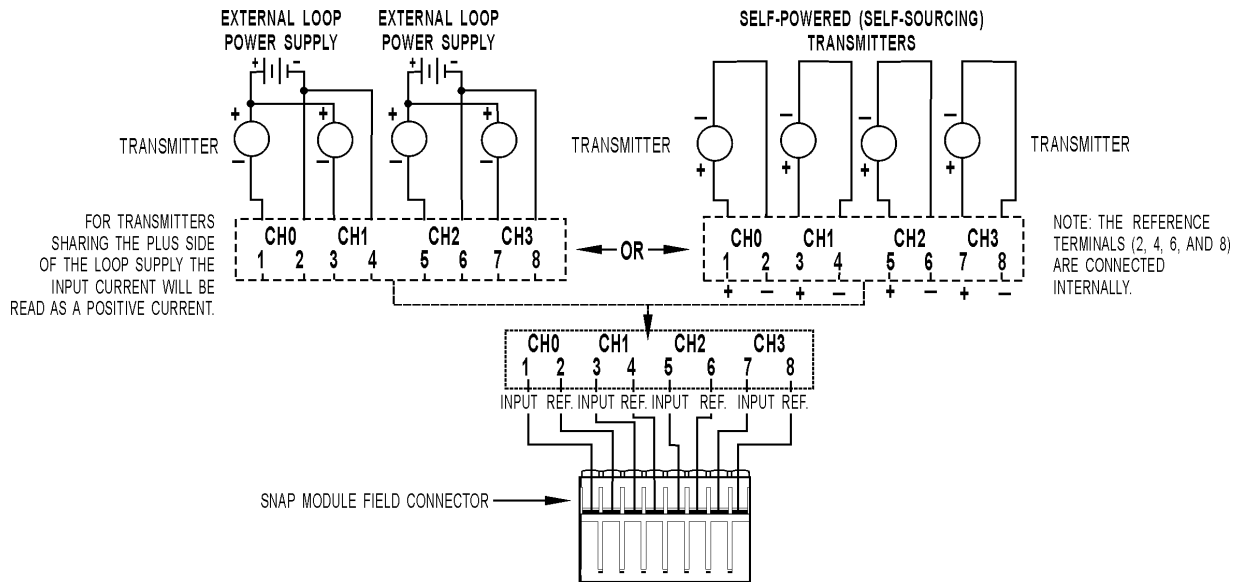

### SNAP-AIMA Wiring: Positive Common vs. Negative Common Connections

The following diagrams apply to SNAP-AIMA-2, SNAP-AIMA-4, and SNAP-AIMA-8 modules.

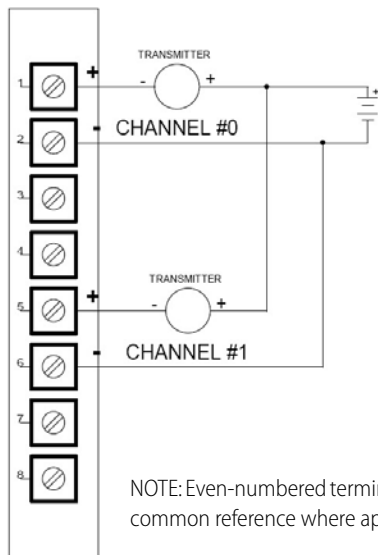

#### SNAP-AIMA

For transmitters sharing the plus side of the loop supply. Note that input current will be read as a positive current.

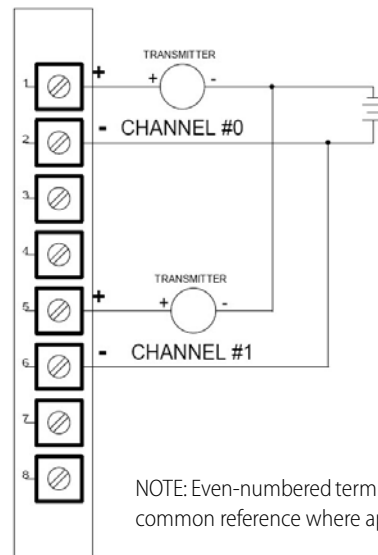

#### SNAP-AIMA

For transmitters sharing the minus side of the loop supply. Note that input current will be read as a negative current.

# SNAP Analog Input Modules

## Current Input Module, -20 mA to +20 mA, Eight Channels

### SNAP-AIMA-8

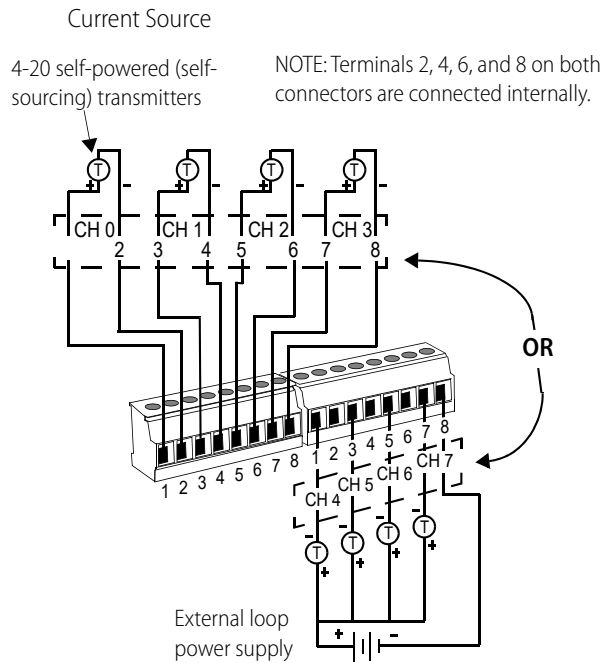

NOTE: For transmitters sharing the plus side of the loop power supply, the input current will be read as a positive current.

See additional wiring diagrams on [page 7](#).

### Description

The SNAP-AIMA-8 module provides an input range of -20mA to +20mA with eight channels of analog current input. (If you need a similar module with 32 channels, see [page 9](#).) The SNAP-AIMA-8 can be used with SNAP PAC brains and rack-mounted controllers only. These modules DO NOT supply loop excitation current.

Since all inputs share a common reference, the module must be installed at the beginning or end of a typical 4–20mA loop. If you are using both standard and self-sourcing transmitters, either put the transmitters on different modules or use different power supplies. If you need channels that are isolated from each other on the same module, see Opto 22 form #1182.

If you have multiple self-sourcing transmitters that share the same positive common, do not use this module. Use the SNAP-AIMA-i module instead. See Opto 22 form #1182.

Part Number	Description
SNAP-AIMA-8	Eight-channel analog current input, -20 mA to +20 mA

### Specifications

Input Range	-20 mA to +20 mA
Over-Range Limits	From -22 to +22 mA (+/-20 mA range)
Resolution	0.8 microamps
Data Freshness (Max)	0.28 seconds
DC Common Mode Rejection	>-120 dB
AC Common Mode Rejection	>-120 dB @ 60 Hz
Maximum Survivable Input	36 mA or 9 VDC
Maximum Operating Common Mode Voltage	250 V
Accuracy	0.05% (10 microamps)
DRIFT: Gain Temperature Coefficient	30 PPM/ °C
DRIFT: Offset Temperature Coefficient	15 PPM/ °C
Isolation	1500 V
Power Requirements	5 VDC (±0.15 ) @ 170 mA
Input Resistance - Single Ended	100 ohms (all channels share the same reference point)
Operating Temperature	-20 °C to 70 °C
Storage Temperature	-40 °C to 85 °C
Torque, hold-down screws	4 in-lb (0.45 N-m)
Torque, connector screws	1.7 in-lb (0.19 N-m)
Agency Approvals	CE, RoHS, DFARS
Warranty	Lifetime





# SNAP Analog Input Modules

## Current Input Module, -20 mA to +20 mA, 32 Channels

### Specifications

Input Range	-20 mA to +20 mA
Over-Range Limits	From -22 to +22 mA (+/-20 mA range)
Resolution	0.8 microamps
Input Filtering	-3 dB @ 31 Hz
Data Freshness (Max)	1.15 s
DC Common Mode Rejection	>-120 dB
AC Common Mode Rejection	>-120 dB @ 60 Hz
Maximum Survivable Input	36 mA or 9 VDC
Maximum Operating Common Mode Voltage	250 V
Accuracy	0.1% (20 microamps)
DRIFT: Gain Temperature Coefficient	30 PPM/ °C
DRIFT: Offset Temperature Coefficient	15 PPM/ °C
Isolation	1500 V, field to logic
Power Requirements	5 VDC (±0.15 ) @ 150 mA
Input Resistance - Single Ended	100 ohms (each channel)
Operating Temperature	-20 °C to 70 °C
Storage Temperature	-40 °C to 85 °C
Torque, hold-down screws	4 in-lb (0.45 N-m)
Torque, connector screws	5.26 in-lb (0.6 N-m)
Agency Approvals	SNAP-AIMA-32: UL, CE, RoHS, DFARS. SNAP-AIMA-32-FM: CE, FM, RoHS, DFARS
Warranty	Lifetime

### Description

The SNAP-AIMA-32 and SNAP-AIMA-32-FM modules provide 32 channels of input with an input range of -20mA to +20mA. The SNAP-AIMA-32-FM is Factory Mutual approved. Check the table on [page 3](#) for I/O processor compatibility. Dimensional drawings are on [page 43](#).



These modules DO NOT supply loop excitation current.

Channels are not isolated from each other. Since all inputs share a common reference, the module must be installed at the beginning or end of a typical 4–20 mA loop. If you use both standard and self-sourcing transmitters, put the

transmitters on different modules or use different power supplies. (If you need channels that are isolated from each other on the same module, see Opto 22 form #1182.)

Part Number	Description
SNAP-AIMA-32 SNAP-AIMA-32-FM	32-channel analog current input, -20 mA to +20 mA
SNAP-HD-BF6	Wiring harness for SNAP-AIMA-32 modules and breakout racks
SNAP-AIMA-HDB SNAP-AIMA-HDB-FM	Breakout racks for SNAP-AIMA-32 and SNAP-AIMA-32-FM

### Wiring

SNAP TEX cables and a breakout rack are available separately for wiring points to field devices (see form #1756, the *SNAP TEX Cables & Breakout Boards Data Sheet*). The SNAP-HD-BF6 cable connects the module to the breakout rack, which can then be wired to field devices. (NOTE: The SNAP-HD-CBF6 wiring harness with flying leads is not recommended for this module.)

**CAUTION:** We strongly recommend that you use the breakout rack with these modules. Miswiring of any point on the module can cause severe out-of-warranty damage. The breakout rack protects the module from many wiring errors.

if you are using the module with loop power (2-wire) negative common devices, connect to the SNAP-AIMA-HDB (or -FM) rack. If you are using the module with self-powered devices (4-wire) or with devices that share a common positive connection, do not use the SNAP-AIMA-HDB (or -FM) boards, which have a current limiting diode. Instead, wire to the SNAP-AIMA-HDB or SNAP-AIMA-HDB-FM.

### Correcting for Inverted Scaling

Positive readings for these modules appear as negative values. Therefore, in order to obtain meaningful readings, use the scaling feature in PAC Control as follows:

1. In the Add or Edit Analog Point dialog box for each point, choose the scalable version of the module.
2. Under Scaling, scale each point negatively as shown below:



# SNAP Analog Input Modules

## 0 to 25,000 Hz Analog Rate Input Module

### Specifications

Nominal Input Range	0 to 25,000 Hz
Input Over-Range	To 27,500 Hz
Resolution	1 Hz
Input Response Time(% of span / delta Hz / delta time)	10.0% / 2,500 Hz / 0.1 sec 63.2% / 15.8 K Hz / 0.9 sec 99.0% / 24.75 K Hz / 4.2 sec
Data Freshness (Max)	126 ms
DC Common Mode Rejection	> -120 dB
AC Common Mode Rejection	> -120 dB at 60 Hz
Maximum Operating Common Mode Voltage	250 V
Accuracy (% full scale)	±4 Hz or ±0.5% of the input frequency (whichever is greater)
Drift: Gain Temperature Coefficient	200 ppm / °C
Drift: Offset Temperature Coefficient	50 ppm / °C
Input Coupling	Single-ended AC (capacitor coupled)
Input Amplitude Sine wave Square wave	2.5 V to 24 V p-p 0.5 V to 24 V p-p
Minimum Pulse Width	18 microseconds
Input Impedance (Inputs share the same reference point.) Pull-up Voltage Pull-up Resistor	50 K ohms AC coupled (-input to +input) 6 to 9 V 4.7 K ohms
Isolation	1500 V
Power Requirements	5 VDC (±0.15 V) at 190 mA
Operating Temperature	-20 °C to 70 °C
Storage Temperature	-40 °C to 85 °C
Wire size	22 to 14 AWG
Torque, hold-down screws	4 in-lb (0.45 N-m)
Torque, connector screws	5.26 in-lb (0.6 N-m)
Agency Approvals	UL, FM, CE, RoHS, DFARS
Warranty	Lifetime

Part Number	Description
SNAP-AIRATE	0–25,000 Hz analog rate input

### Description

The SNAP-AIRATE module provides two channels of frequency-to-digital conversion. The nominal input range is 0 to 25,000 Hz with an over-range capability to 27,500 Hz. Nine volts through a 4.7 K ohm pull-up resistor are provided internally for use with devices that have open collector outputs. This feature eliminates the need for the user to provide the pull-up voltage supply and associated wiring, barrier strips, etc.

The module works with TTL, CMOS, and open collector outputs. Truly a two-wire hookup, the SNAP-AIRATE module is ideally suited for use with a tachometer.

Please note that this module does not provide channel-to-channel isolation. If you need isolated channels, see the [SNAP Isolated Analog Input Modules Data Sheet](#), form 1182.



# SNAP Analog Input Modules

## 0 to 25,000 Hz Analog Rate Input Module (continued)

SNAP-AIRATE Wiring Diagrams

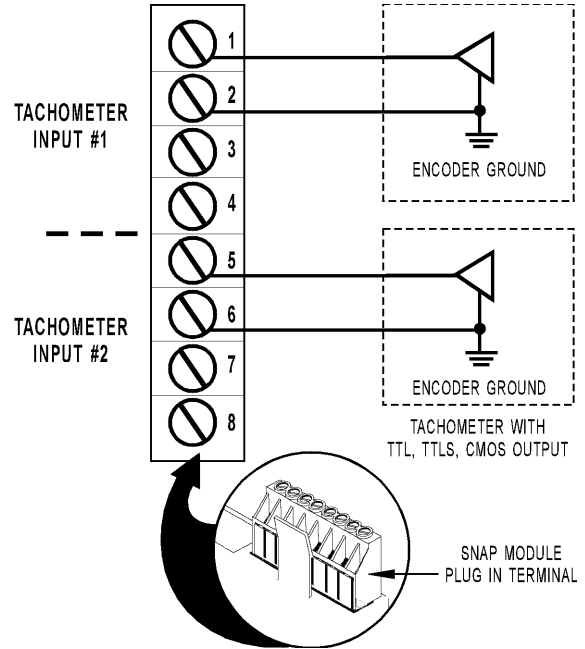
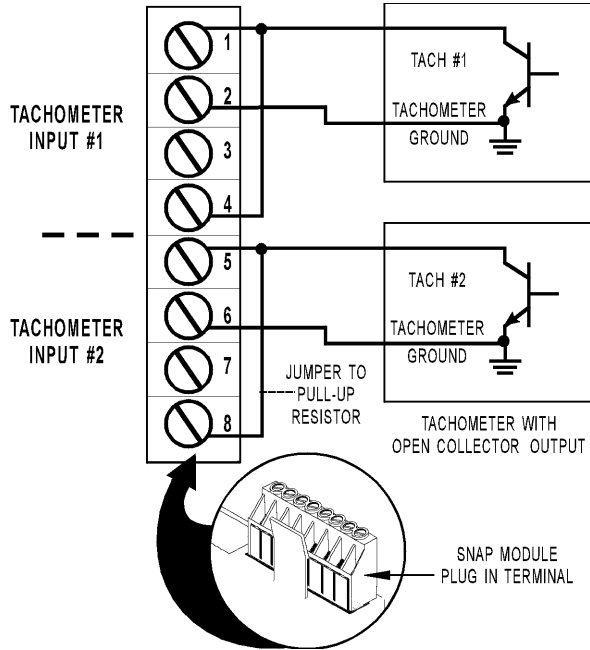

NOTE: This module does not provide channel-to-channel isolation.

# SNAP Analog Input Modules

## Thermistor Input Module 0–40 K, 0–20 K, 0–10 K, or 0–5 K Ohm

### SNAP-AIR40K-4

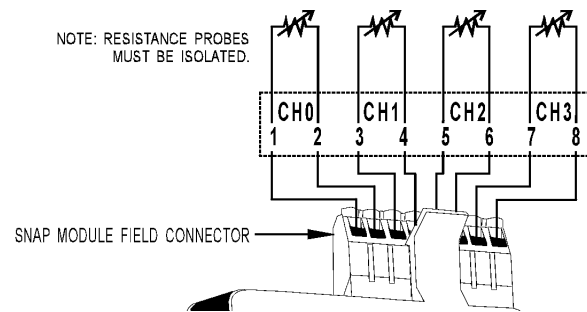

IMPORTANT: The mounting rack connector has 24 pins; the module connector has 20 pins. The extra pins on the mounting rack connector prevent misalignment of the module during installation.

### Description

The SNAP-AIR40K-4 module provides four channels of analog to digital conversion, ideal for thermistors used in HVAC applications or for reading the resistance of potentiometer input. See the table on [page 3](#) for I/O processor compatibility.

The default input range is 0 to 40 K Ohms. The module can also be configured for 0 to 20 K, 0 to 10 K, or 0 to 5 K Ohms.

NOTE: Resistance probes must be isolated from each other.



Part Number	Description
SNAP-AIR40K-4	Four-channel analog resistor/thermistor input, 40 K Ohms, 20 K Ohms, 10 K Ohms, or 5 K Ohms

### Specifications

Input Range	0 to 40,000 Ohms 0 to 20,000 Ohms 0 to 10,000 Ohms 0 to 5,000 Ohms
Maximum Over-Range	44 K (40 K Ohms range) 22 K (20 K Ohms range) 11 K (10 K Ohms range) 5.5 K (5 K Ohms range)
Resolution	1.6 Ohm @ 40 K Ohms 0.8 Ohm @ 20 K Ohms 0.4 Ohm @ 10 K Ohms 0.2 Ohm @ 5 K Ohms
Input Filtering	-3 dB @ 3.2 Hz
Data Freshness (Max)	100 (40 K Ohms) 200 (20 K Ohms) 400 (10 K Ohms) 800 (5 K Ohms)
DC Common Mode Rejection	>-120 dB
AC Common Mode Rejection	>-120 dB @ 60 Hz
Maximum Operating Common Mode Voltage	250 V
Accuracy	0.1% ± 40 Ohms @ 40 K Ohms 0.1% ± 20 Ohms @ 20 K Ohms 0.1% ± 10 Ohms @ 10 K Ohms 0.1% ± 5 Ohms @ 5 K Ohms
DRIFT: Gain Temperature Coefficient	30 PPM/ °C
DRIFT: Offset Temperature Coefficient	15 PPM/ °C
Isolation	1500 V
Power Requirements	5 VDC (±0.15 ) @ 190 mA
Operating Temperature	-20 °C to 70 °C
Storage Temperature	-40 °C to 85 °C
Wire size	22 to 14 AWG
Torque, hold-down screws	4 in-lb (0.45 N-m)
Torque, connector screws	5.26 in-lb (0.6 N-m)
Agency Approvals	UL, FM, CE, RoHS, DFARS
Warranty	Lifetime

## Thermistor Input Module 0–400 K, 0–200 K, 0–100 K, 0–50 K, 0–40 K, 0–20 K, 0–10 K, 0–5 K, 0–4 K, 0–2 K, 0–1 K, 0–500 Ohm

### SNAP-AIR400K-8

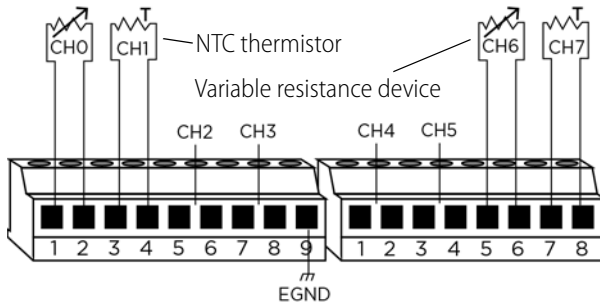

**IMPORTANT:** The mounting rack connector has 24 pins; the module connector has 20 pins. The extra pins on the mounting rack connector prevent misalignment of the module during installation.

### Description

The SNAP-AIR400K-8 module has eight channels of analog to digital conversion that convert resistance to temperature or to Ohms. The module is ideal for NTC thermistors commonly used in HVAC, refrigeration, and process control applications. It may also be used with PTC thermistors in resistance sensing applications. See the table on [page 3](#) for I/O processor compatibility.



## SNAP Analog Input Modules

Part Number	Description
SNAP-AIR400K-8	Eight channel analog resistor/thermistor input, 400 K Ohms, 200 K Ohms, 100 K Ohms, 50 K Ohms, 40 K Ohms, 20 K Ohms, 10 K Ohms, 5 K Ohms, 4 K Ohms, 2 K Ohms, 1 K Ohms, 500 Ohms

The SNAP-AIR400K-8 reads variable resistance type transducers, and it has 12 resistance input ranges from 500 Ohms to 400 K Ohms, plus Autorange. Range dependent resolution is from 20 milliOhms to 16 Ohms.

SNAP PAC brains and PAC Control provide direct temperature readings for four popular thermistors using the [Steinhart-Hart equation](#) (see [page 16](#)). You may also enter custom coefficients for unsupported thermistor curves.

The simple two-wire connections are made to the pluggable terminal strip on top of the module.

*NOTE: The eight input channels must be electrically isolated from each other and earth ground. The transducer resistor element must be isolated from any electrically conducting probe tube housing.*

See [page 15](#) for module specifications.

### Wiring Information

Unshielded 24 AWG wire (minimum) is recommended.

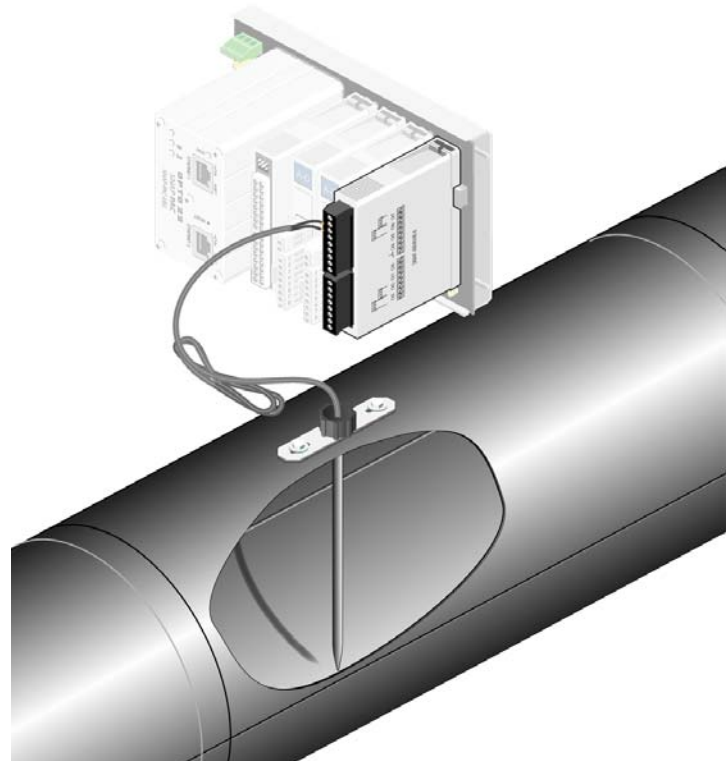



# SNAP Analog Input Modules

## Thermistor Input Module 0–400 K (continued)

### Specifications

Input Ranges	400 K, 200 K, 100 K, 50 K, 40 K, 20 K, 10 K, 5 K, 4 K, 2 K, 1 K, 500 Ohms, and Autorange					
Resolution	<u>Resolution</u> 16 Ohm 8 Ohm 4 Ohm 2 Ohm	<u>Range</u> 0 to 400 kOhms 0 to 200 kOhms 0 to 100 kOhms 0 to 50 kOhms	<u>Resolution</u> 1.6 Ohm 0.8 Ohm 0.4 Ohm 0.2 Ohm	<u>Range</u> 0 to 40 kOhms 0 to 20 kOhms 0 to 10 kOhms 0 to 5 kOhms	<u>Resolution</u> 0.16 Ohm 0.08 Ohm 0.04 Ohm 0.02 Ohm	<u>Range</u> 0 to 4 kOhms 0 to 2 kOhms 0 to 1 kOhms 0 to 500 Ohms
Accuracy (Ohms @ Range) 0.1% Reading + 2x Range Resolution + 1 Ohm	400 Ohms @ 400 K 200 Ohms @ 200 K 100 Ohms @ 100 K 0 Ohms @ 50 K		40 Ohms @ 40 K 20 Ohms @ 20 K 10 Ohms @ 10 K 5 Ohms @ 5 K		4 Ohms @ 4 K 2 Ohms @ 2 K 1 Ohms @ 1 K 0.5 Ohms @ 500	
Data Freshness	1.61 seconds maximum					
DSP Notch Filter	20 Hz (-3DB = 5.24 Hz)					
Excitation Current Nominal (Range & Load Watts Dissipation)	9uA (50 K–4.1 uW), (100 K–8.1 uW), (200 K–16 uW), (400 K–32 uW) 90uA (5 K–40 uW), (10 K–81 uW), (20 K–160 uW), (40 K–320 uW) 200uA (500 K–20 uW), (1 K–40 uW), (2 K–80 uW), (4 K–160 uW)					
Autorange Step Time	1.6 seconds to next higher or lower range >= 10 seconds for a 500 Ohms to 400 K Ohms step change					
Autorange Ohms Hysteresis	<p><b>Ranges</b></p> <p><b>Ohms Open &gt; 440K</b></p> <p>20K between 200K &amp; 400K 10K between 100K &amp; 200K 5K between 50K &amp; 100K</p> <p>19K between 40K &amp; 50K 2K between 20K &amp; 40K 1K between 10K &amp; 20K 500 between 5K &amp; 10K</p> <p>1.9K between 4K &amp; 5K 200 between 2K &amp; 4K 100 between 1K &amp; 2K 50 between 500 &amp; 1K</p>					
DC Common Mode Rejection	>-120 dB					
AC Common Mode Rejection	>-120 dB @ 60 Hz					
Open Resistor Indicator	Channel resistance = 999,999.999 Ohms					
PAC Control Reads	temperature reading or -32768 Ohms if over or under range					
Maximum Operating Common Mode Voltage (Field Term to Logic Connector)	500 VDC or peak VAC					
Drift Gain Tempco Offset Tempco	30 PPM / °C 15 PPM / °C					
Power Requirements	5 VDC (±0.15 ) @ 190 mA					
Operating Temperature	-20 °C to 70 °C					
Storage Temperature	-40 °C to 85 °C					
Torque, hold-down screws	4 in-lb (0.45 N-m)					
Torque, connector screws	5.26 in-lb (0.6 N-m)					
Agency Approvals	UL, CE					
Warranty	Lifetime					

## SNAP Analog Input Modules

### Thermistor Input Module 0–400 K (continued)

#### Auto-range Curves

The following table shows temperatures in °C and °F that correlate with resistance values in Ohms for the generic curve types for four popular thermistors using the [Steinhart-Hart equation](#). Choose the curve type for your application in PAC Control or PAC Manager when you configure a SNAP-AIR400K-8 module. (For custom curves, see [page 17](#).)

Choose a 2-wire thermistor value with a resistance over the target temperature range that is much larger than the lead resistance for your application

Lower value curves (2252 or 3K) work best at cooler temperatures (< 25 °C or 77 °F) because long lead wire resistance can add significant errors to the measurement.

SNAP-AIR400K-8 Auto-range Curves Table

Temp °C	Temp °F	2252 curve	3K curve	10K type 3 curve	10K type 2 curve
		Resistance (Ohms)			
-40	-40	75,769.0	100,935.0	239,686.0	336,450.0
-35	-31	54,647.0	72,798.0	179,200.0	242,660.0
-30	-22	39,851.0	53,088.0	135,185.0	176,960.0
-25	-13	29,368.0	39,123.0	102,861.0	130,410.0
-20	-4	21,861.0	29,122.0	78,913.0	97,072.0
-15	5	16,429.0	21,885.0	61,020.0	72,951.0
-10	14	12,459.0	16,598.0	47,543.0	55,326.0
-5	23	9,532.0	12,698.0	37,313.0	42,326.0
0	32	7,353.0	9,795.0	29,490.0	32,650.0
5	41	5,718.0	7,617.0	23,457.0	25,391.0
10	50	4,481.0	5,970.0	18,780.0	19,899.0
15	59	3,538.0	4,713.0	15,130.0	15,711.0
20	68	2,813.0	3,748.0	12,263.0	12,492.0
25	77	2,252.0	3,000.0	10,000.0	10,000.0
30	86	1,814.0	2,417.0	8,194.0	8,057.0
35	95	1,471.0	1,959.0	6,752.0	6,531.0
40	104	1,200.0	1,598.0	5,592.0	5,326.0
45	113	983.8	1,311.0	4,655.0	4,368.0
50	122	811.2	1,081.0	3,893.0	3,602.0
55	131	672.5	895.8	3,271.0	2,986.0
60	140	560.3	746.3	2,760.0	2,488.0
65	149	469.0	624.8	2,339.0	2,083.0
70	158	394.5	525.5	1,990.0	1,752.0
75	167	333.1	443.8	1,700.0	1,479.0

# SNAP Analog Input Modules

SNAP-AIR400K-8 Auto-range Curves Table (continued)

Temp °C	Temp °F	2252 curve	3K curve	10K type 3 curve	10K type 2 curve
		Resistance (Ohms)			
80	176	282.7	376.6	1,458.0	1,255.0
85	185	240.9	320.9	1,255.0	1,070.0
90	194	206.2	274.6	1,084.0	915.4
95	203	177.1	236.0	939.3	786.6
100	212	152.8	203.6	816.8	678.6
105	221	132.3	176.3	712.6	587.6
110	230	115.0	153.2	623.6	510.6
115	239	100.3	133.6	547.3	445.2
120	248	87.7	116.9	481.8	389.6
125	257	77.0	102.6	425.3	341.9
130	266	67.8	90.3	376.4	301.0
135	275	59.9	79.7	334.0	265.8
140	284	53.0	70.6	297.2	235.4
145	293	47.1	62.7	265.1	209.0
150	302	41.9	55.8	237.0	186.1

The information in this table is provided by Automation Components, Inc.

## Custom Curves

To configure the SNAP-AIR400K-8 with custom curves, follow these steps:

1. Configure the I/O unit in PAC Control, PAC Manager, or EtherNet/IP Configurator, and save the configuration to flash memory.
2. Open PAC Manager and choose Tools > Inspect.
3. In the Device Name field, enter the I/O unit's IP address. Click the Point Config button in the left navigation.
4. Choose the module number and point number you want to configure.
5. Click in the Value column next to Point Type and choose Temperature from the dropdown menu.
6. Scroll down and click the Value column next to Thermistor Curve. Choose Unknown.
7. For each coefficient (A, B, K, C), click the Value column and enter your custom coefficient.
8. Click the Apply button at right.
9. Save the configuration to flash memory: Click the Status Write button, under Operation highlight Store configuration to flash, and click Send Command.

# SNAP Analog Input Modules

## RTD Input Modules

SNAP-AIRTD, SNAP-AIRTD-1K, and SNAP-AIRTD-10

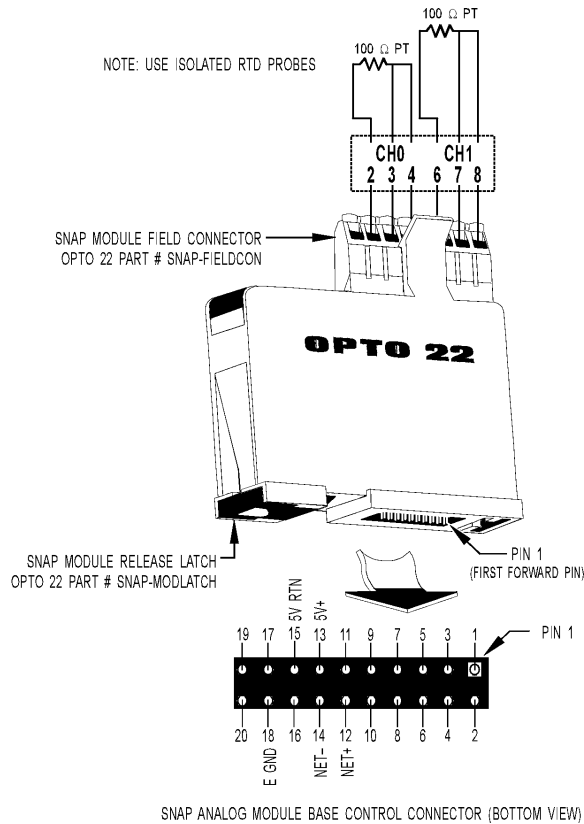

**IMPORTANT:** The mounting rack connector has 24 pins; the module connector has 20 pins. The extra pins on the mounting rack connector prevent misalignment of the module during installation.

### Description

The SNAP-AIRTD and SNAP-AIRTD-1K platinum and the SNAP-AIRTD-10 copper modules are usually used for temperature inputs. They can also be used to make high-resolution resistance measurements.

On all three modules, the two inputs share the same reference terminal. Make sure you use isolated RTD probes.

The SNAP-AIRTD-10 and SNAP-AIRTD-1K require a SNAP PAC brain or R-series controller.

Also see the SNAP-AIRTD-8U module on [page 20](#).

Part Number	Description
SNAP-AIRTD-1K	Two-channel 1000 ohm platinum RTD input
SNAP-AIRTD	Two-channel 100 ohm platinum RTD input
SNAP-AIRTD-10	Two-channel 10 ohm copper RTD input

### Wiring

RTD input modules are designed for three-wire connections, shown in the diagram below.

If you use a four-wire connection (shown at the bottom right), **DO NOT** connect the fourth wire, as it will cause errors in the readings.

Two-wire connections are not recommended, as they will degrade accuracy and stability.

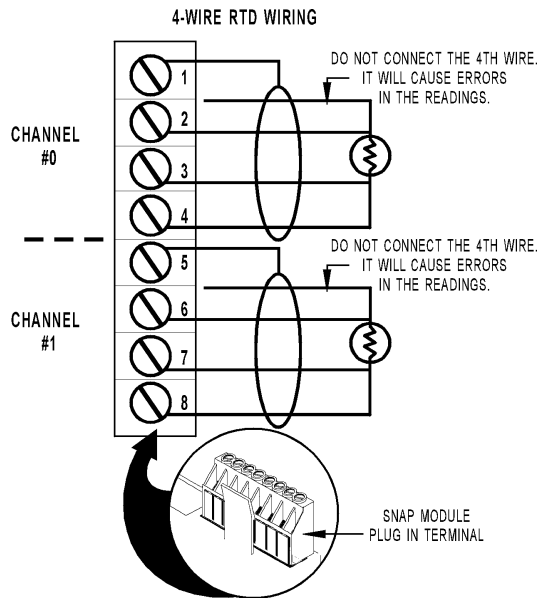
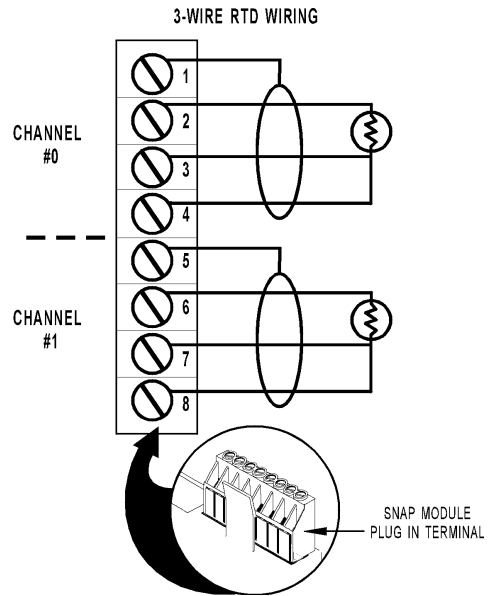

# SNAP Analog Input Modules

## RTD Input Modules (continued)

### Specifications

	SNAP-AIRTD-1K	SNAP-AIRTD	SNAP-AIRTD-10
3-wire RTD input	1000 ohm platinum @ 0 °C $\alpha = 0.00385$ 1000 ohm nickel @ 0 °C $\alpha = 0.00618$ 1000 ohm nickel @ 70 °F $\alpha = 0.00637$	100 ohm platinum; $\alpha = 0.00385$ 100 ohm nickel, -60 to 250 °C 120 ohm nickel, -80 to 260 °C	10 ohm copper; $\alpha = 0.00428$
Input Temperature Range	-200 °C to 850 °C (-328° to +1,582° F)	-200 °C to 850 °C (-328° to +1,582° F)	-180 °C to 260 °C (-292° to +500° F)
Input Range	0 to 4000 ohms	0 to 400 ohms	0 to 25 ohms
Over-Range Limit	to 4400 ohms	to 440 ohms	to 27.5 ohms
Resolution (average)	0.042 °C (0.16 ohms)	0.042 °C (0.016 ohms)	0.026 °C (0.001 ohms)
Input Filtering	-3 dB @ 0.1 Hz	-3 dB @ 0.1 Hz	-3 dB @ 100 Hz
Data Freshness (Max)	100 ms	100 ms	168 ms
Lead Compensation	Automatic when used with SNAP brains	Automatic when used with SNAP brains	Automatic when used with SNAP PAC brains
DC Common Mode Rejection	>-120 dB	>-120 dB	>-120 dB
AC Common Mode Rejection	>-120 dB at 60 Hz	>-120 dB at 60 Hz	>-120 dB at 60 Hz
Excitation (typical)	0.256 mA constant current	1.25 mA constant current	5.4 mA constant current
Maximum Lead Resistance	40 ohms single wire (all leads to be equal resistance)	40 ohms single wire (all leads to be equal resistance)	15 ohms single wire (all leads to be equal resistance)
Maximum Fault Voltage at Input (between any 2 field wires)	±15 V	±15 V	±15 V
Maximum Operating Common Mode Voltage	250 V	250 V	250 V
Accuracy From factory After setting gain and offset	0.8 °C 0.6 °C	0.8 °C 0.6 °C	0.6 °C 0.5 °C
Isolation	1500 V	1500 V	1500 V
Power Requirements	5.00 to 5.20 VDC @ 190 mA	5.00 to 5.20 VDC @ 190 mA	5.00 to 5.20 VDC @ 190 mA
Operating Temperature	-20 °C to 70 °C	-20 °C to 70 °C	-20 °C to 70 °C
Storage Temperature	-40 °C to 85 °C	-40 °C to 85 °C	-40 °C to 85 °C
Wire size	22 to 14 AWG	22 to 14 AWG	22 to 14 AWG
Torque, hold-down screws	4 in-lb (0.45 N-m)	4 in-lb (0.45 N-m)	4 in-lb (0.45 N-m)
Torque, connector screws	5.26 in-lb (0.6 N-m)	5.26 in-lb (0.6 N-m)	5.26 in-lb (0.6 N-m)
Agency Approvals	CE, RoHS, DFARS	UL, FM, CE, RoHS, DFARS	CE, RoHS, DFARS
Warranty	Lifetime	Lifetime	Lifetime

## RTD Input Modules (continued)

### SNAP-AIRTD-8U



#### Description

The SNAP-AIRTD-8U provides 8 input channels, each individually software configurable. This module is commonly used for 3-wire RTD temperature inputs but is also suited to high-resolution resistance measurements. It features open circuit detection if any wire breaks.

All 8 inputs share the same reference terminal. Make sure you use isolated RTD probes.

The SNAP-AIRTD-8U requires a SNAP PAC brain or R-series controller with firmware R9.5a or higher. The module cannot be used with legacy brains or controllers.

#### Point Configuration

See table at right. You can individually configure each of the module's 8 points for a variety of behaviors:

- **Temperature**—Range is fixed. Default range is 0–8000 ohms. Choose nickel, platinum, or copper RTD input. The data returned is degrees C or degrees F, depending on your choice for the I/O unit.
- **Fixed-range** (default)—Choose the range you want to use. If the value goes above the limit for that range, an out-of-range value (16-bit) of –32768 is displayed. The data returned is resistance in ohms.
- **Full Auto-range**—The module scrolls up and down the entire set of ranges and dynamically chooses the appropriate range for best resolution. Note that this point type can result in higher latency when ranging up (see Specifications on next page). The data returned is resistance in ohms.

## SNAP Analog Input Modules

Part Number	Description
SNAP-AIRTD-8U	8-channel multifunction 3-wire RTD/resistance input

#### Point Configuration (continued)

- **Auto-range Down**—The module scrolls down and up within the specified range limit. If the value goes above the specified range, an out-of-range value (16-bit) of –32768 is displayed. These point types allow auto-ranging within the selected range but limit the data latency when ranging up. The data returned is resistance in ohms.

**Point configuration choices** for each of the 8 inputs (default is highlighted in gray):

Point Type	Range*
1k Ohm at 70 °F Ni	-46 to +148.9 °C
1k Ohm at 0 °C Ni	-40 to +135 °C
1k Ohm Pt	-200 to +850 °C
120 Ohm Ni	-80 to +260 °C
100 Ohm Ni	-60 to +250 °C
100 Ohm Pt	-200 to +850 °C
10 Ohm Cu	-60 to +355 °C
Fixed-range (Default)	0 - 8000 Ohms
Fixed-range	0 - 4000 Ohms
Fixed-range	0 - 2000 Ohms
Fixed-range	0 - 1000 Ohms
Fixed-range	0 - 800 Ohms
Fixed-range	0 - 400 Ohms
Fixed-range	0 - 200 Ohms
Fixed-range	0 - 100 Ohms
Fixed-range	0 - 80 Ohms
Fixed-range	0 - 40 Ohms
Fixed-range	0 - 20 Ohms
Fixed-range	0 - 10 Ohms
Full Auto-range	0 - 8000 Ohms
Auto-range Down	0 - 4000 Ohms
Auto-range Down	0 - 2000 Ohms
Auto-range Down	0 - 1000 Ohms
Auto-range Down	0 - 800 Ohms
Auto-range Down	0 - 400 Ohms
Auto-range Down	0 - 200 Ohms
Auto-range Down	0 - 100 Ohms
Auto-range Down	0 - 80 Ohms
Auto-range Down	0 - 40 Ohms
Auto-range Down	0 - 20 Ohms
Auto-range Down	0 - 10 Ohms

\* Maximum range; actual range depends on your probe.



# SNAP Analog Input Modules

## RTD Input Modules (continued)

### Wiring

The SNAP-AIRTD-8U has a plug-in terminal on top with spring-clamp connectors for easy wiring. An insertion tool is provided in the box with the module.

For each connection:

1. Insert the tool in the small square hole and push down.
2. Push the wire firmly into the rectangular hole below the tool, and then remove the tool.

The module is designed for 3-wire RTDs, shown below. All wires must be the same size. If you use a 4-wire connection,

DO NOT connect the fourth wire, as it will cause errors in the readings. If you use 2-wire RTDs (not recommended because measurement is less accurate), you must jumper terminal 2 to 3 for each applicable RTD channel.

### A Note on Calibration

Because the SNAP-AIRTD-8U uses intermittent excitation current for measurements, it cannot be used with RTD calibrators that require a steady excitation current.

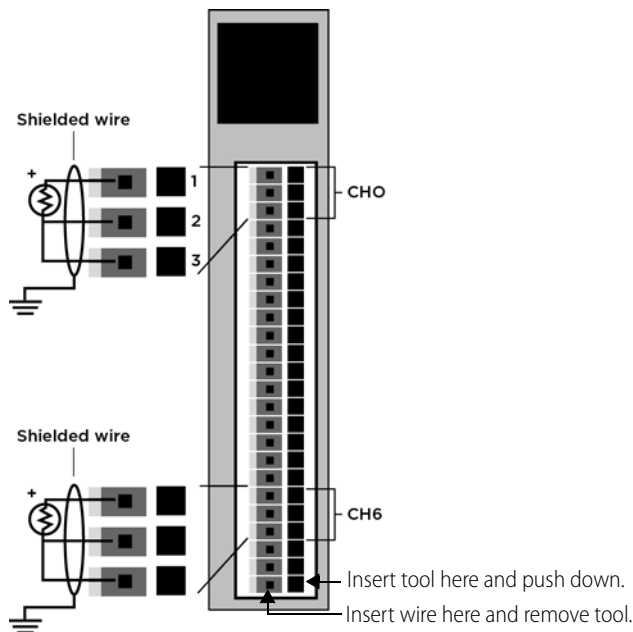

**IMPORTANT:** The mounting rack connector has 24 pins; the module connector has 20 pins. The extra pins on the mounting rack connector prevent misalignment of the module during installation.

# SNAP Analog Input Modules

## RTD Input Modules (continued)

### Specifications

	SNAP-AIRTD-8U		
3-wire RTD input and maximum temperature table range (actual range depends on your probe)	1000 ohm platinum @ 0 °C $\alpha= 0.00385$ Range: -200 to 850 °C (-328 to 1,582 °F)	100 ohm platinum @ 0 °C $\alpha= 0.00385$ Range: -200 °C to 850 °C (-328 to 1,582 °F)	10 ohm copper @ 25 °C $\alpha= 0.00427$ Range: -60 to 355 °C (-76 to 671 °F)
	1000 ohm nickel @ 0 °C $\alpha= 0.00618$ Range: -60 to 170 °C (-76 to 356 °F)	100 ohm nickel @ 0 °C $\alpha= 0.00618$ Range: -60 to 250 °C (-76 to 482 °F)	
	1000 ohm nickel @ 70 °F $\alpha= 0.00637$ Range: -46 to 148.9 °C (-50 to 300 °F)	120 ohm nickel @ 0 °C $\alpha= 0.00672$ Range: -80 to 260 °C (-112 to 500 °F)	
Input Range	0 to 4000 ohms	0 to 400 ohms	0 to 40 ohms
Accuracy From factory After setting gain and offset	0.8 °C (Pt); 0.6 °C (Ni) 0.6 °C (Pt); 0.4 °C (Ni)	0.8 °C (Pt); 0.6 °C (Ni) 0.6 °C (Pt); 0.4 °C (Ni)	1.7 °C 1.2 °C
Excitation Current	4.28 mA	2 mA	0.325 mA
Over-Range Limit	10% overrange for all measurements in ohms		
Resolution In Ohms In RTD Temperature	The greater of: (Ohms Range / 100,000) or 1 milliohm Better than or equal to 0.05 °C (0.09 °F)		
Input Filtering Front end filtering DSP Notch filter	-15 dB @ 50 Hz, -20 dB @ 60 Hz 20 Hz (-3 DdB = 5.24 Hz)		
Data Freshness (Max)	1.2 s		
Auto-range Settle Time Step change from 10 to 8000 Step change from 8000 to 10	1.2 s to the next higher or lower range ≤ 10 s ranging up (channel may show overrange until settled) ≤ 10 s ranging down (channel will give a reading while settling)		
Total Lead Resistance	200 ohms maximum		
DC Common Mode Rejection	>-120 dB		
AC Common Mode Rejection	>-120 dB at 60 Hz		
Maximum Survivable Fault Voltage at Input (between any 2 field wires)	±8 V		
Maximum Operating Common Mode Voltage	250 V field terminal to logic connector		
Isolation	1500 V field side to logic side		
Power Requirements	5.00 to 5.20 VDC @ 135 mA		
Operating Temperature	-20 °C to 70 °C		
Storage Temperature	-40 °C to 85 °C		
Maximum wire size	20 AWG		
Torque, hold-down screws	4 in-lb (0.45 N-m)		
Agency Approvals	UL, CE, RoHS, DFARS		
Warranty	Lifetime		

# SNAP Analog Input Modules

## ICTD Temperature Input Module, Two or Four Channels

### SNAP-AICTD (Two channels)

Four-channel module wiring is shown on the next page.

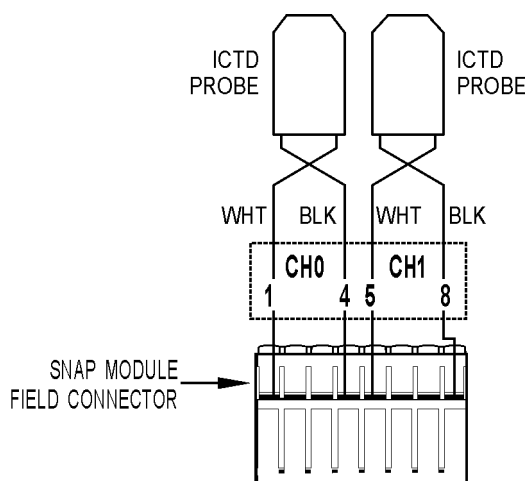

**IMPORTANT:** The mounting rack connector has 24 pins; the module connector has 20 pins. The extra pins on the mounting rack connector prevent misalignment of the module during installation.



Part Number	Description
SNAP-AICTD	Two-channel analog temperature input, ICTD
SNAP-AICTD-4	Four-channel analog temperature input, ICTD

### Description

SNAP-AICTD and SNAP-AICTD-4 modules provide temperature input data from any industry-standard Integrated Circuit Temperature Device (ICTD). The SNAP-AICTD has two channels, and the SNAP-AICTD-4 has four channels. See the table on [page 3](#) for I/O processor compatibility.

The simple two-wire connections are made to the pluggable terminal strip on top of the module. Up to 2,000 feet of ordinary hook-up wire is used to connect the sensor to the input terminal strip.

Both modules are compatible with all industry-standard ICTD probes, including the AD-590 family from Analog Devices and Opto 22's part number ICTD.

### Specifications

Input Range with ICTD Probe	-40 °C to +100 °C
Module Input Range Zero Scale Full Scale	-273 °C +150 °C
Resolution	0.017 °C
Accuracy with ICTD Probe	±0.8 °C
Sensitivity	1.0 microamps/ °C
Data Freshness (Max)	167 ms (2-channel module) 355 ms (4-channel module)
DC Common Mode Rejection	>-120 dB
AC Common Mode Rejection	>-120 dB @ 60 Hz
Maximum Operating Common Mode Voltage	250 V
Isolation	1500 V
Power Requirements	5 VDC (± .015 ) @ 150 mA
Operating Temperature	-20 °C to 70 °C
Storage Temperature	-40 °C to 85 °C
Wire size	22 to 14 AWG
Torque, hold-down screws	4 in-lb (0.45 N-m)
Torque, connector screws	5.26 in-lb (0.6 N-m)
Agency Approvals	UL, FM, CE, RoHS, DFARS

# SNAP Analog Input Modules

Warranty	Lifetime
----------	----------

## ICTD Temperature Input Module (continued)

### SNAP-AICTD-4 (Four channels)

Two-channel module wiring is shown on the previous page.

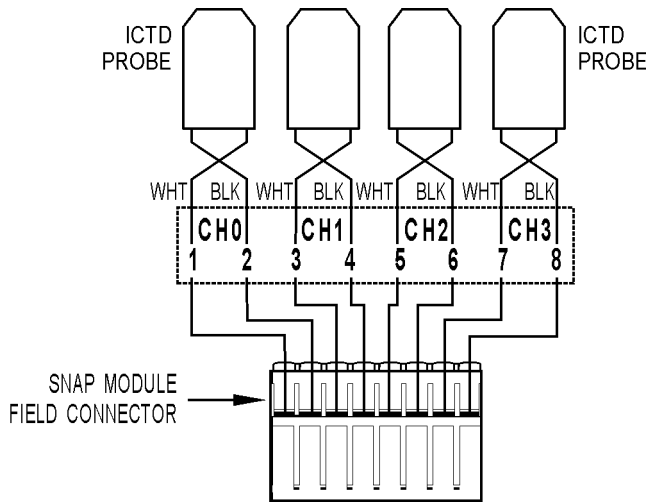

**IMPORTANT:** The mounting rack connector has 24 pins; the module connector has 20 pins. The extra pins on the mounting rack connector prevent misalignment of the module during installation.

# SNAP Analog Input Modules

## ICTD Temperature Input Module, Eight Channels

### SNAP-AICTD-8

ICTD Source

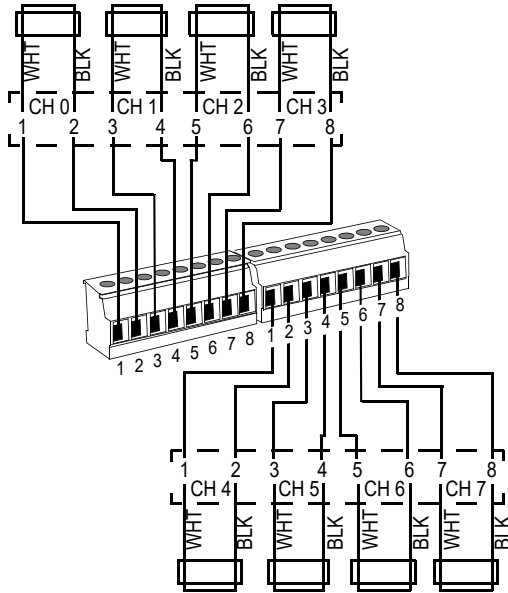

NOTE: Terminals 2, 4, 6, and 8 on both connectors are connected internally.



Part Number	Description
SNAP-AICTD-8	Eight-channel analog temperature input, ICTD

### Description

The SNAP-AICTD-8 module provides temperature input data from any industry-standard Integrated Circuit Temperature Device (ICTD). It has eight channels of input. The SNAP-AICTD-8 can be used only with SNAP PAC brains and rack-mounted controllers (standard wired and Wired+Wireless models).

The simple two-wire connections are made to the terminal strip on top of the module. Up to 2,000 feet of ordinary hook-up wire is used to connect the sensor to the input terminal strip.

The module is compatible with all industry-standard ICTD probes, including the AD-590 family from Analog Devices and Opto 22's part number ICTD.

### Specifications

Input Range with ICTD Probe	-40 °C to +100 °C
Module Input Range	
Zero Scale	-273 °C
Full Scale	+150 °C
Data Freshness (Max)	0.28 seconds
Resolution	0.017 °C
Accuracy with ICTD Probe	±0.8 °C
Sensitivity	1.0 mA/ °C
DC Common Mode Rejection	>-120 dB
AC Common Mode Rejection	>-120 dB @ 60 Hz
Maximum Operating Common Mode Voltage	250 V
Isolation	1500 V
Power Requirements	5 VDC (± .015 ) @ 170 mA
Operating Temperature	-20 °C to 70 °C
Storage Temperature	-40 °C to 85 °C
Torque, hold-down screws	4 in-lb (0.45 N-m)
Torque, connector screws	1.7 in-lb (0.19 N-m)
Agency Approvals	CE, RoHS, DFARS
Warranty	Lifetime

## Thermocouple/Millivolt Input Module

### SNAP-AITM

#### Thermocouple Polarity and Range

Type	-	+	Range
E	Red	Purple	-270°C to +1,000 °C
J	Red	White	-210°C to +1,200 °C
K	Red	Yellow	-270°C to +1,372 °C

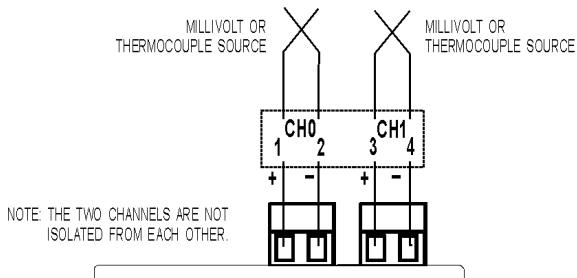

IMPORTANT: The mounting rack connector has 24 pins; the module connector has 20 pins. The extra pins on the mounting rack connector prevent misalignment of the module during installation.

### Description

The SNAP-AITM module provides two channels of analog to digital conversion. Each channel on the module can be configured for -150 mV DC to +150 mV DC or -75 mV DC to +75 mV DC, or for type E, J, or K thermocouple operation.

Since both inputs share the same reference terminal, use isolated probes for thermocouple inputs. If you need isolated channels on the same module, see Opto 22 form #1182.



## SNAP Analog Input Modules

Part Number	Description
SNAP-AITM	Two-channel analog type E, J, or K thermocouple or -150 mV to +150 mV input or -75 mV to +75 mV input

### Specifications

Input Range	From -150 mV to +150 mV From -75 mV to +75 mV
Over-Range Limits	From -165 to +165 mV (+/-150 mV range) From -82.5 to +82.5 mV (+/-75 mV range)
Resolution	6 microvolts from -150 to +150 mV 3 microvolts from -75 to +75 mV
Cold Junction Temperature Compensation	Automatic when used with SNAP I/O processors
Input Filtering	-3 dB @ 7 Hz
Input Response Time (% of span/delta V/delta time)	63.2%/95 mV/23 mS
Data Freshness (Max)	167 ms (+/-150 mV) 334 ms (+/-75 mV)
DC Common Mode Rejection	>-120 dB
AC Common Mode Rejection	>-120 dB @ 60 Hz
Maximum Survivable Input	±15 volts
Maximum Operating Common Mode Voltage	250 V
Accuracy at Full Scale	0.06% (90 microvolts) @ 150 mV 0.1% (75 microvolts) @ 75 mV
Drift: Gain Temperature Coefficient	5 microvolts / °C
Drift: Offset Temperature Coefficient	2 microvolts / °C
Thermocouple Accuracy [°C] From factory After user gain and offset commands	± 2.0 (E, J, and K) ± 0.8
Isolation	1500 V
Power Requirements	5 VDC (±0.15) @ 170 mA
Input Resistance	100 Megohms (each channel)
Ambient Temperature: Operating Storage	-20 °C to 70 °C -40 °C to 85 °C
Torque, hold-down screws	4 in-lb (0.45 N-m)
Torque, connector screws	3 in-lb (0.34 N-m)
Agency Approvals	FM, CE, RoHS, DFARS
Warranty	Lifetime



# SNAP Analog Input Modules

## Thermocouple/Millivolt Input Module

### SNAP-AITM-2

#### Thermocouple Polarity and Range

Type	-	+	Range
B	RED	GRAY	+42° C to +1,820 °C
C, D, G	RED	WHITE	0° C to +2,320 °C
N	RED	ORANGE	-270° C to +1,300 °C
R, S	RED	BLACK	-50° C to +1,768 °C
T	RED	BLUE	-270° C to +400 °C

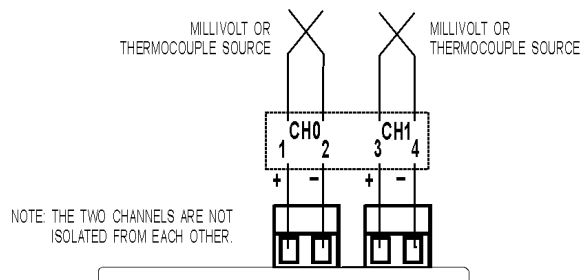

IMPORTANT: The mounting rack connector has 24 pins; the module connector has 20 pins. The extra pins on the mounting rack connector prevent misalignment of the module during installation.

#### Description

The SNAP-AITM-2 module provides an input range of  $\pm 50$  mV,  $\pm 25$  mV, or Type B, C, D, G, N, T, R, or S thermocouple.

Since both inputs share the same reference terminal, use isolated probes for thermocouple inputs. If you need isolated channels on the same module, see Opto 22 form #1182.



Part Number	Description
SNAP-AITM-2	Two-channel analog type B, C, D, G, N, T, R, or S thermocouple or -50 mV to +50 mVDC input or -25 mV to +25 mVDC input

#### Specifications

Input Range	From -50 mV to +50 mVDC From -25 mV to +25 mVDC
Over-range Limits	From -55 to +55 mV (+/-50 mV range) From -27.5 to +27.5 mV (+/-25 mV range)
Resolution	2 microvolts from -50 mV to +50 mV 1 microvolts from -25 mV to +25 mV
Cold Junction Temperature Compensation	Automatic when used with SNAP brains
Input Filtering	-3 dB @ 2.4 Hz
Input Response Time (% of span/delta V/delta time)	63.2%/31.5 mV/66 ms
Data Freshness (Max)	167 ms (+/- 50 mV) 334 ms (+/- 25 mV)
DC Common Mode Rejection	>-120 dB
AC Common Mode Rejection	>-120 dB @ 60 Hz
Maximum Survivable Input	$\pm 15$ volts
Maximum Operating Common Mode Voltage	250 V
Accuracy at Full Scale	0.1% (50 microvolts) @ 50 mV 0.2% (50 microvolts) @ 25 mV
Drift: Gain Temperature Coefficient	5 microvolts / °C
Drift: Offset Temperature Coefficient	2 microvolts / °C
Thermocouple Accuracy [°C]	B, R, S    C, D, G    T, N
From factory	$\pm 5$ $\pm 4$ $\pm 3$
After user gain and offset commands	$\pm 3$ $\pm 2$ $\pm 2$
Isolation	1500 V
Power Requirements	5 VDC ( $\pm 0.15$ ) @ 170 mA
Input Resistance	100 Megohms (each channel)
Ambient Temperature: Operating Storage	-20 °C to 70 °C -40 °C to 85 °C
Agency Approvals	FM, CE, RoHS, DFARS
Torque, hold-down screws	4 in-lb (0.45 N-m)
Torque, connector screws	3 in-lb (0.34 N-m)
Warranty	Lifetime

# SNAP Analog Input Modules

## Thermocouple/Millivolt Input Module

### SNAP-AITM-8 and SNAP-AITM-8-FM

#### Thermocouple Polarity and Range

Type	-	+	Range
B	RED	GRAY	+42° C to +1,820 °C
C, D, G	RED	WHITE	0° C to +2,320 °C
E	RED	PURPLE	-270°C to +1,000 °C
J	RED	WHITE	-210°C to +1,200 °C
K	RED	YELLOW	-270°C to +1,372 °C
N	RED	ORANGE	-270° C to +1,300 °C
R, S	RED	BLACK	-50° C to +1,768 °C
T	RED	BLUE	-270° C to +400 °C

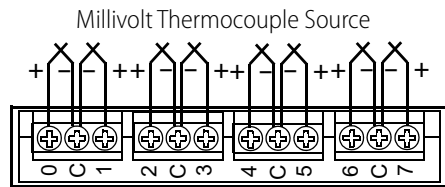

Common terminals are connected internally.

NOTE: For best accuracy, wire all points before calibrating, and short all unused channels.

The SNAP-AITM-8-FM is Factory Mutual approved.



### Description

The SNAP-AITM-8 and SNAP-AITM-8-FM modules provide eight channels of analog to digital conversion. Each channel on the module can be configured for -75 mV DC to +75 mV DC, -50 mV DC to +50 mV DC, -25 mV DC to +25 mV DC, or for type B, C, D, E, G, J, K, N, R, S or T thermocouple operation.

Since all inputs share the same reference terminal, use isolated probes for thermocouple inputs. See the dimensional diagram on [page 40](#).

Part Number	Description
SNAP-AITM-8 SNAP-AITM-8-FM	8-channel B, C, D, E, G, J, K, N, R, S, or T thermocouple or -75 mV to +75 mV, 50 mV to +50 mV, or 25 mV to +25 mV input

### Specifications

Input Range	From -75 mV to +75 mV From -50 mV to +50 mV From -25 mV to +25 mV
Over-Range Limits	From -82.5 to +82.5 mV (+/-75 mV range) From -55 to +55 mV (+/-50 mV range) From -27.5 to +27.5 mV (+/-25 mV range)
Resolution	3 microvolts from -75 mV to +75 mV 2 microvolts from -50 mV to +50 mV 1 microvolts from -25 mV to +25 mV
Cold Junction Temperature Compensation	Automatic when used with SNAP I/O processors
Input Filtering	-3 dB @ 5 Hz
Data Freshness (Max)	2.25 s
DC Common Mode Rejection	>-120 dB
AC Common Mode Rejection	>-120 dB @ 60 Hz
Maximum Survivable Input	±15 volts
Max Operating Common Mode Voltage	250 V
Accuracy at Full Scale	0.1% (75 microvolts) @ 75 mV 0.1% (50 microvolts) @ 50 mV 0.2% (50 microvolts) @ 25 mV
Drift: Gain Temperature Coefficient	5 microvolts / °C
Drift: Offset Temperature Coefficient	2 microvolts / °C
Thermocouple Accuracy [°C]	E, J, K    B, R, S    C, D, G    T, N
From factory	±2.0    ±5    ±4    ±3
After user gain and offset commands	±0.5    ±3    ±2    ±2
Isolation	1500 V
Power Requirements	5 VDC (±0.15) @ 200 mA
Input Resistance	100 Megohms (each channel)
Ambient Temperature: Operating Storage	-20 °C to 70 °C -40 °C to 85 °C
Torque, hold-down screws	4 in-lb (0.45 N-m)
Torque, connector screws	3 in-lb (0.34 N-m)
Agency Approvals	SNAP-AITM-8: UL, CE, RoHS, DFARS SNAP-AITM-8-FM: FM, CE, RoHS, DFARS
Warranty	Lifetime

# SNAP Analog Input Modules

## 0 to 250 Volt RMS AC/DC Input Module

### SNAP-AIVRMS

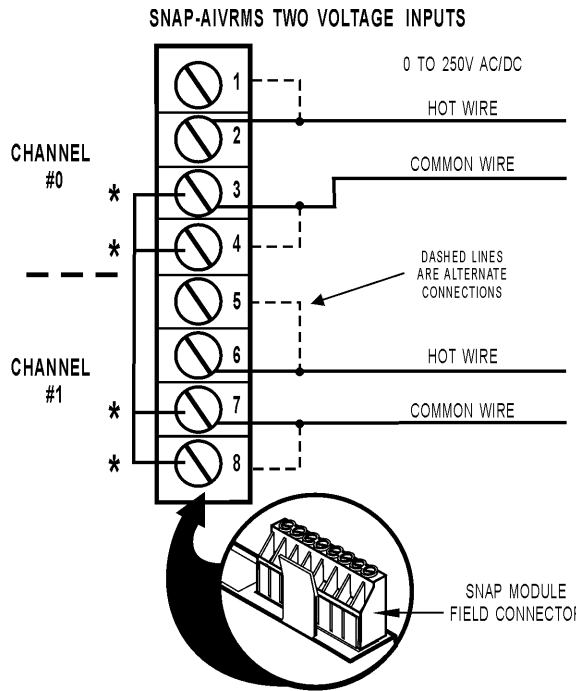

\*Terminals 3,4,7,8 are connected together internally.

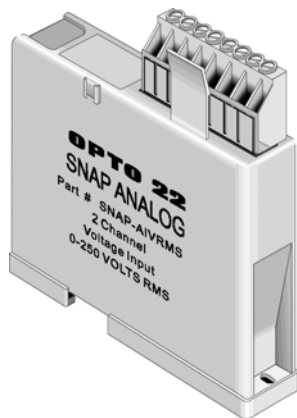

Part Number	Description
SNAP-AIVRMS	Two-channel 0 to 250 V RMS AC/DC input

### Description

The SNAP-AIVRMS module provides an input range of 0 to 250 volts AC or DC. The SNAP-AIVRMS module may be used to monitor 120/240-volt AC/DC and 12/24/48-volt AC/DC system voltage.

Terminals 3, 4, 7, and 8 share a common connection inside the module. Make sure you observe polarity when connecting the second channel. To avoid a potentially hazardous short, double-check wiring before turning on the voltage to be monitored.

If you need a module with channel-to-channel isolation, see form #1182, the *SNAP Isolated Analog Input Modules Data Sheet*.

### Specifications

Input Range	0 to 250 V RMS AC/DC
Input Over-Range	To 275 V
Input Resistance	1 M ohms
Accuracy	±0.2 V and ±0.2% reading
Resolution	10 mV
DC Reversal	± 0.4 V (.16%)
Input Response Time (Step Change)	5% (12.5 V) in 100 mS 63.2% (158 V) in 200 mS 99% (248 V) in 1200 mS
Data Freshness (Max)	32.3 ms
DC Common Mode Rejection	>-120 dB
AC Common Mode Rejection	>-120 dB @ 60 Hz
Maximum Operating Common Mode Voltage	250 V
Isolation	1500 V
Power Requirements	5 VDC (±0.15 V) at 170 mA
Operating Temperature	-20 °C to 70 °C
Storage Temperature	-40 °C to 85 °C
Wire size	22 to 14 AWG
Torque, hold-down screws	4 in-lb (0.45 N-m)
Torque, connector screws	5.26 in-lb (0.6 N-m)
Agency Approvals	UL, FM, CE, RoHS, DFARS
Warranty	Lifetime

# SNAP Analog Input Modules

## Voltage Input Module, -10 VDC to +10 VDC or -5 VDC to +5 VDC, Two or Four Channels

### SNAP-AIV (Two channels)

Four-channel module wiring is shown on [page 31](#).

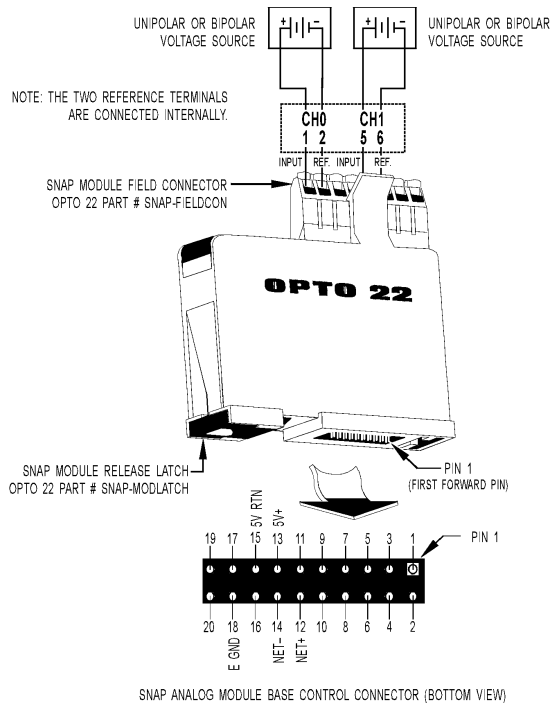

**IMPORTANT:** The mounting rack connector has 24 pins; the module connector has 20 pins. The extra pins on the mounting rack connector prevent misalignment of the module during installation.

### Description

The SNAP-AIV and SNAP-AIV-4 modules can be configured for either -10VDC to +10VDC or -5VDC to +5VDC operation on each channel. The SNAP-AIV provides two channels, and the SNAP-AIV-4 four. If you need a module with more channels, see [page 32](#). See the table on [page 3](#) for I/O processor compatibility.

Note that all channels share a common reference terminal. If you need two isolated channels on the same module, see Opto22 form #1182.

Part Number	Description
SNAP-AIV	Two-channel analog voltage input -10 to +10 VDC
SNAP-AIV-4	Four-channel analog voltage input -10 to +10 VDC

### Specifications

Input Range	From -10 volts to +10 volts From -5 volts to +5 volts
Over-Range Limits	From -11 to +11 volts (+/-10 V range) From -5.5 to +5.5 volts (+/-5 V range)
Resolution	0.4 mV when configured -10 to +10 volts 0.2 mV when configured -5 to +5 volts
Input Filtering	-3 dB @ 64 Hz
Input Response Time (% of span/ delta V / delta t)	63.2% / 6.7 V / 10 ms
Data Freshness (Max)	11.5 ms (2-channel, +/- 10 VDC) 23 ms (2-channel, +/- 5 VDC) 23 ms (4-channel, +/- 10 VDC) 46 ms (4-channel, +/- 5 VDC)
DC Common Mode Rejection	>-120 dB
AC Common Mode Rejection	>-120 dB @ 60 Hz
Maximum Survivable Input	220 VAC or 300 VDC
Maximum Operating Common Mode Voltage	250 V
Accuracy	0.05%, 5 mV @ 10 VDC 2.5 mV @ 5 VDC
Gain Temperature Coefficient	30 PPM/ °C
Offset Temperature Coefficient	15 PPM/ °C
Isolation	1500 V
Power Requirements	5 VDC (±0.15) @ 170 mA
Input Resistance	1 M ohms (each channel; both channels share the same reference point)
Ambient Temperature: Operating Storage	-20 °C to 70 °C -40 °C to 85 °C
Wire size	22 to 14 AWG
Torque, hold-down screws	4 in-lb (0.45 N-m)
Torque, connector screws	5.26 in-lb (0.6 N-m)
Agency Approvals	UL, FM, CE, RoHS, DFARS
Warranty	Lifetime

# SNAP Analog Input Modules

## Voltage Input Module, -10 VDC to +10 VDC or -5 VDC to +5 VDC, Four Channels (continued)

### SNAP-AIV-4 (Four channels)

Two-channel module wiring is shown on the previous page.

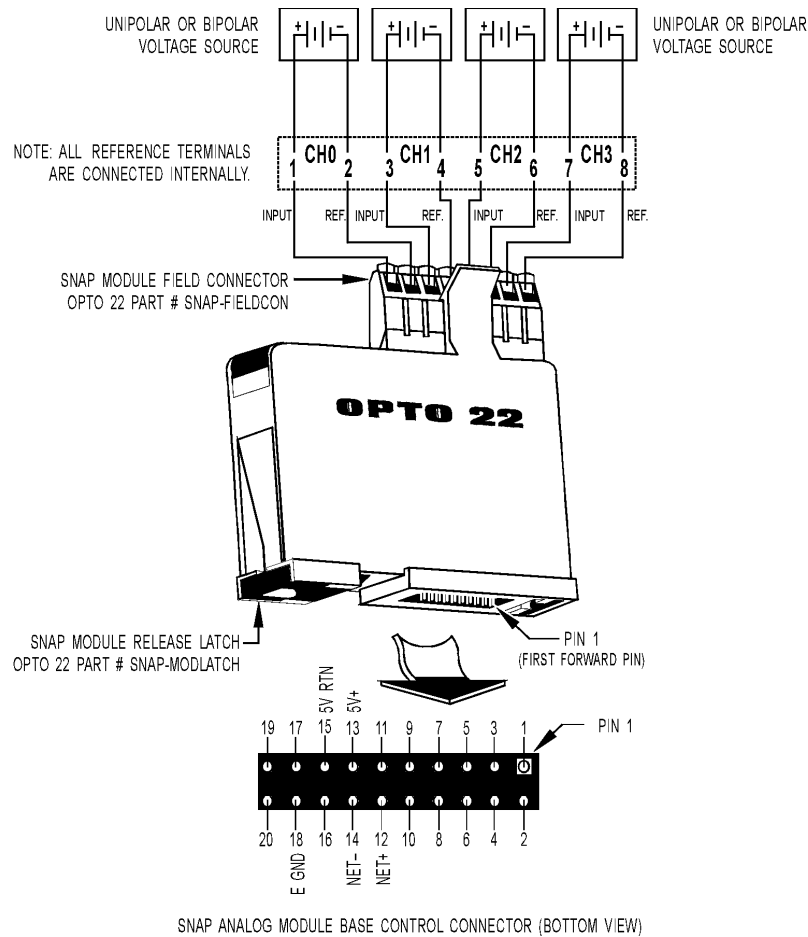

**IMPORTANT:** The mounting rack connector has 24 pins; the module connector has 20 pins. The extra pins on the mounting rack connector prevent misalignment of the module during installation.

# SNAP Analog Input Modules

## Voltage Input Module, -10 VDC to +10 VDC or -5 VDC to +5 VDC, Eight Channels

### SNAP-AIV-8

Voltage Source

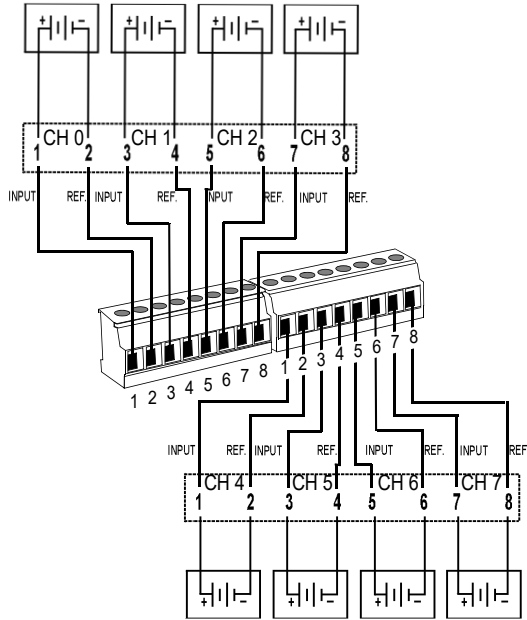

NOTE: Terminals 2, 4, 6, and 8 on both connectors are connected internally.

### Description

The SNAP-AIV-8 module can be configured for either -10 VDC to +10 VDC or -5 VDC to +5 VDC operation on each of its eight input channels. (If you need a module with more channels, see [page 33](#).) The SNAP-AIV-8 can be used only with SNAP PAC brains and rack-mounted controllers (standard wired and Wired+Wireless models).



Part Number	Description
SNAP-AIV-8	Eight-channel analog voltage input -10 to +10 VDC

Note that all channels share a common reference terminal. If you need two isolated channels on the same module, see Opto22 form #1182.

### Specifications

Input Range	From -10 volts to +10 volts From -5 volts to +5 volts
Over-Range Limits	From -11 to +11 volts (+/-10 V range) From -5.5 to +5.5 volts (+/-5 V range)
Resolution	0.4 mV when configured -10 to +10 volts 0.2 mV when configured -5 to +5 volts
Input Filtering	-3 dB @ 64 Hz
Data Freshness (Max)	0.28 seconds
DC Common Mode Rejection	>-120 dB
AC Common Mode Rejection	>-120 dB @ 60 Hz
Maximum Survivable Input	220 VAC or 300 VDC
Maximum Operating Common Mode Voltage	250 V
Accuracy	0.05%, 5 mV @ 10 VDC 2.5 mV @ 5 VDC
Gain Temperature Coefficient	30 PPM/ °C
Offset Temperature Coefficient	15 PPM/ °C
Isolation	1500 V
Power Requirements	5 VDC (±0.15) @ 170 mA
Input Resistance	1 M ohms (all channels share the same reference point)
Ambient Temperature: Operating Storage	-20 °C to 70 °C -40 °C to 85 °C
Torque, hold-down screws	4 in-lb (0.45 N-m)
Torque, connector screws	1.7 in-lb (0.19 N-m)
Agency Approvals	CE, RoHS, DFARS
Warranty	Lifetime



# SNAP Analog Input Modules

## Voltage Input Module, -10 VDC to +10 VDC or -5 VDC to +5 VDC, 32 Channels

### Specifications

Input Range	From -10 volts to +10 volts From -5 volts to +5 volts
Over-Range Limits	From -11 to +11 volts (+/-10 V range) From -5.5 to +5.5 volts (+/-5 V range)
Resolution	0.4 mV when configured -10 to +10 volts 0.2 mV when configured -5 to +5 volts
Input Filtering	-3 dB @ 31 Hz
Data Freshness (Max)	1.1 s
DC Common Mode Rejection	>-120 dB
AC Common Mode Rejection	>-120 dB @ 60 Hz
Maximum Survivable Input	220 VAC or 300 VDC
Maximum Operating Common Mode Voltage	250 V
Accuracy	0.05%, 5 mV @ 10 VDC 2.5 mV @ 5 VDC
Gain Temperature Coefficient	30 PPM/ °C
Offset Temperature Coefficient	15 PPM/ °C
Isolation	1500 V
Power Requirements	5 VDC (±0.15) @ 150 mA
Input Resistance	1 M ohms (each channel; all channels share the same reference point)
Ambient Temperature: Operating Storage	-20 °C to 70 °C -40 °C to 85 °C
Torque, hold-down screws	4 in-lb (0.45 N-m)
Torque, connector screws	5.26 in-lb (0.6 N-m)
Agency Approvals	SNAP-AIV-32: UL, CE, RoHS, DFARS SNAP-AIV-32-FM: FM, CE, RoHS, DFARS
Warranty	Lifetime

Part Number	Description
SNAP-AIV-32 SNAP-AIV-32-FM	32-channel analog voltage input -10 to +10 VDC
SNAP-HD-CBF6	Wiring harness with flying leads for SNAP-AIV-32 modules
SNAP-HD-BF6	Wiring harness for SNAP-AIV-32 modules and SNAP-AIV-HDB breakout racks
SNAP-AIV-HDB SNAP-AIV-HDB-FM	Breakout racks for SNAP-AIV-32 and SNAP-AIV-32-FM

### Description

The SNAP-AIV-32 and SNAP-AIV-32-FM modules can be configured for either -10 VDC to +10 VDC or -5 VDC to +5 VDC operation on each of its 32 channels. See the table on [page 3](#) for I/O processor compatibility. The SNAP-AIV-32-FM is Factory Mutual approved.

Note that all channels share a common reference terminal. (For channel-to-channel isolated modules, see Opto22 form #1182.)

SNAP TEX cables and a breakout rack are available separately for wiring points to field devices (see form #1756, the *SNAP TEX Cables & Breakout Boards Data Sheet*). The SNAP-HD-BF6 wiring harness connects the module to the breakout rack, which can then be wired to field devices. The SNAP-HD-CBF6 wiring harness has flying leads to connect to field devices.

See the dimensional drawing for the module on [page 43](#).





# SNAP Analog Input Modules

## Voltage Input Module -10 VDC to +10 VDC or -5 VDC to +5 VDC (continued)

**Wiring diagram: SNAP-AIV-HDB breakout rack to SNAP-AIV-32 or SNAP-AIV-32-FM module**

NOTE: This diagram is also used to wire the SNAP-AIV-HDB breakout rack to a SNAP-AIMA-32 or SNAP-AIMA-32-FM module, when the module connects to self-powered (4-wire) device.

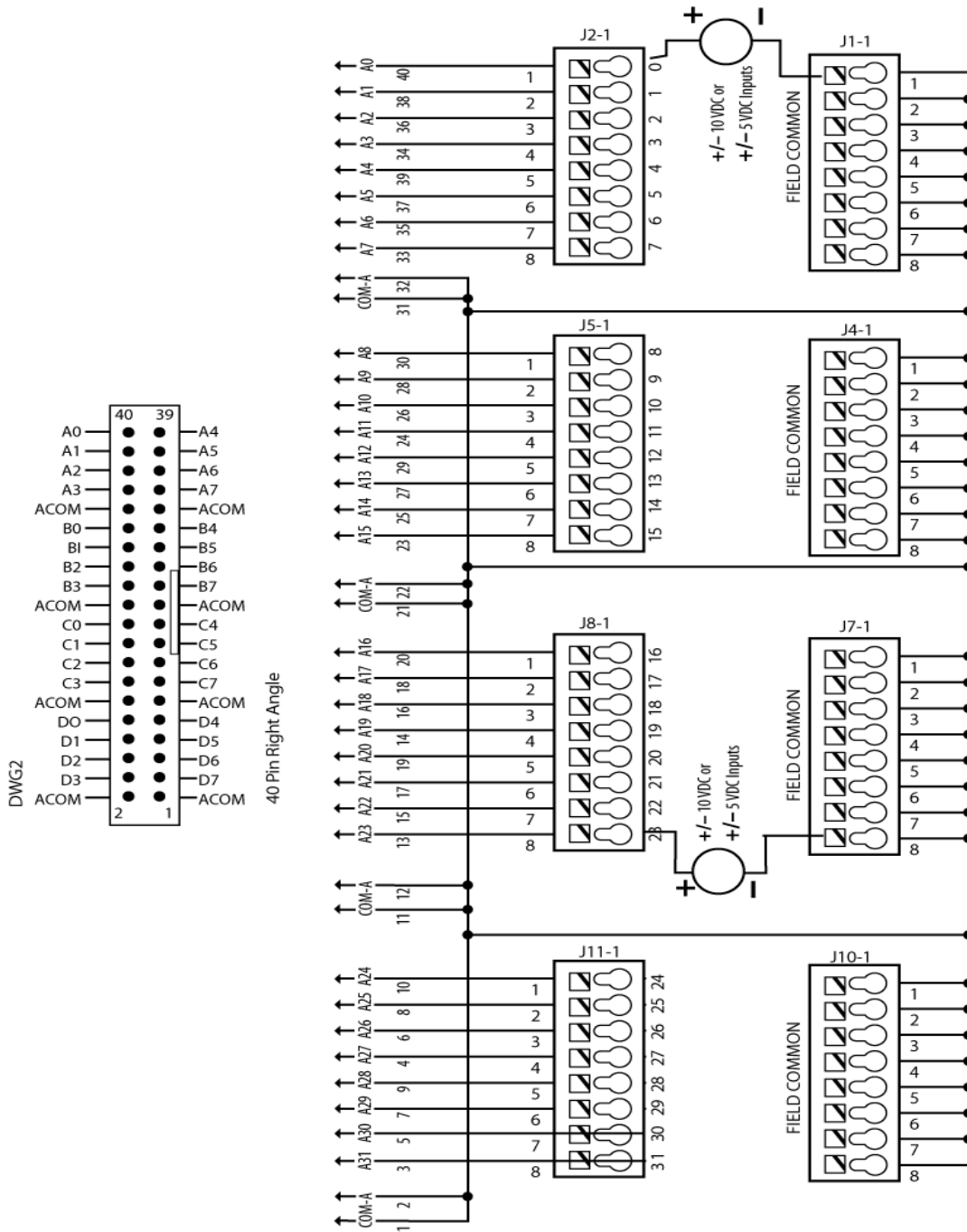

# SNAP Analog Input Modules

## Millivolt Input Module

### SNAP-AIMV2-4

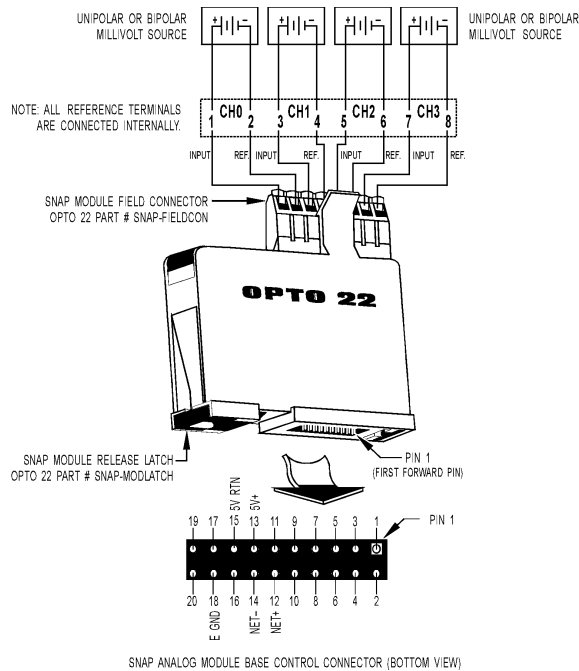

**IMPORTANT:** The mounting rack connector has 24 pins; the module connector has 20 pins. The extra pins on the mounting rack connector prevent misalignment of the module during installation.

### Description

The SNAP-AIMV2-4 module provides four channels of analog to digital conversion. See the table on [page 3](#) for I/O processor compatibility.

Each channel on the module can be configured for -50 mV DC to +50 mV DC or -25 mV DC to +25 mV DC.

Note that all inputs share the same reference terminal.

Part Number	Description
SNAP-AIMV2-4	Four-channel -50 to +50 mV input or -25 mV to +25 mV input

### Specifications

Input Range	From -50 mV to +50 mV From -25 mV to +25m V
Over-Range Limits	From -55 to +55 mV (+/-50 mV range) From -27.5 to +27.5 mV (+/-25 mV range)
Resolution	2 microvolts (-50 mV to +50 mV) 1 microvolt (-25 mV to +25 m V)
Input Filtering	-3 dB @ 2.4Hz
Input Response Time (% of span/delta V/delta time)	63.2%/31.5 mV/66 ms
Data Freshness (Max)	335 ms (+/- 50 mV) 668 ms (+/- 25 mV)
DC Common Mode Rejection	>-120 dB
AC Common Mode Rejection	>-120 dB @ 60 Hz
Maximum Survivable Input	±15 volts
Maximum Operating Common Mode Voltage	250 V
Accuracy at Full Scale	0.1% (50 microvolts) @ 50m V 0.2% (50 microvolts) @ 25 mV
Drift: Gain Temperature Coefficient	3 microvolts / °C
Drift: Offset Temperature Coefficient	2 microvolts / °C
Isolation	1500 V
Power Requirements	5 VDC (±0.15 ) @ 170 mA
Input Resistance - Single Ended	100 Megohms (each channel)
Operating Temperature	-20 °C to 70 °C
Storage Temperature	-40 °C to 85 °C
Wire size	22 to 14 AWG
Torque, hold-down screws	4 in-lb (0.45 N-m)
Torque, connector screws	5.26 in-lb (0.6 N-m)
Agency Approvals	UL, FM, CE, RoHS, DFARS
Warranty	Lifetime

## Millivolt Input Module

### SNAP-AIMV-4

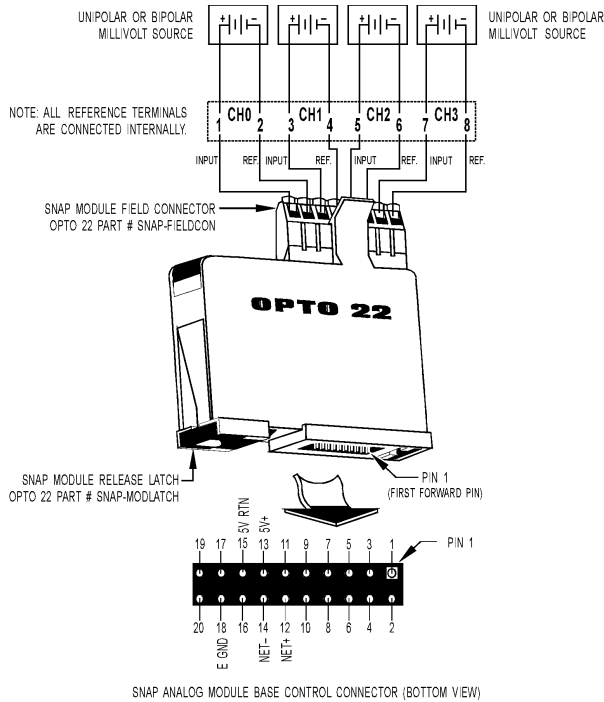

**IMPORTANT:** The mounting rack connector has 24 pins; the module connector has 20 pins. The extra pins on the mounting rack connector prevent misalignment of the module during installation.

### Description

The SNAP-AIMV-4 module provides four channels of analog to digital conversion. See the table on [page 3](#) for I/O processor compatibility.

Each channel on the module can be configured for -150 mV DC to +150 mV DC or -75 mV DC to +75 mV DC.

Note that all inputs share the same reference terminal.

## SNAP Analog Input Modules

Part Number	Description
SNAP-AIMV-4	Four-channel -150 to +150 mV or -75 to +75 mV input

### Specifications

Input Range	From -150 mV to +150 mV From -75 mV to +75m V
Over-Range Limits	From -165 to +165 mV (+/-150 mV range) From -82.5 to +82.5 mV (+/-75 mV range)
Resolution	6 microvolts (-150 mV to +150 mV) 3 microvolts (-75 mV to +75 mV)
Input Filtering	-3 dB @ 7 Hz
Input Response Time (% of span/delta V/delta time)	63.2%/95 mV/23 ms
Data Freshness (Max)	335 ms (+/- 150 mV) 668 ms (+/- 75 mV)
DC Common Mode Rejection	>-120 dB
AC Common Mode Rejection	>-120 dB @ 60 Hz
Maximum Survivable Input	±15 volts
Maximum Operating Common Mode Voltage	250 V
Accuracy at Full Scale	0.06% (90 microvolts) @ 150 mV 0.1% (75 microvolts) @ 75 mV
Drift: Gain Temperature Coefficient	3 microvolts / °C
Drift: Offset Temperature Coefficient	2 microvolts / °C
Isolation	1500 V
Power Requirements	5 VDC (±0.15 ) @ 170 mA
Input Resistance - Single Ended	100 Megohms (each channel)
Operating Temperature	-20 °C to 70 °C
Storage Temperature	-40 °C to 85 °C
Wire size	22 to 14 AWG
Torque, hold-down screws	4 in-lb (0.45 N-m)
Torque, connector screws	5.26 in-lb (0.6 N-m)
Agency Approvals	UL, FM, CE, RoHS, DFARS
Warranty	Lifetime

# SNAP Analog Input Modules

## Alternate Wiring Diagram

SNAP-AIV-HDB breakout rack to SNAP-AIMA-32 or SNAP-AIMA-32-FM module when the module connects to devices that share a positive common connection

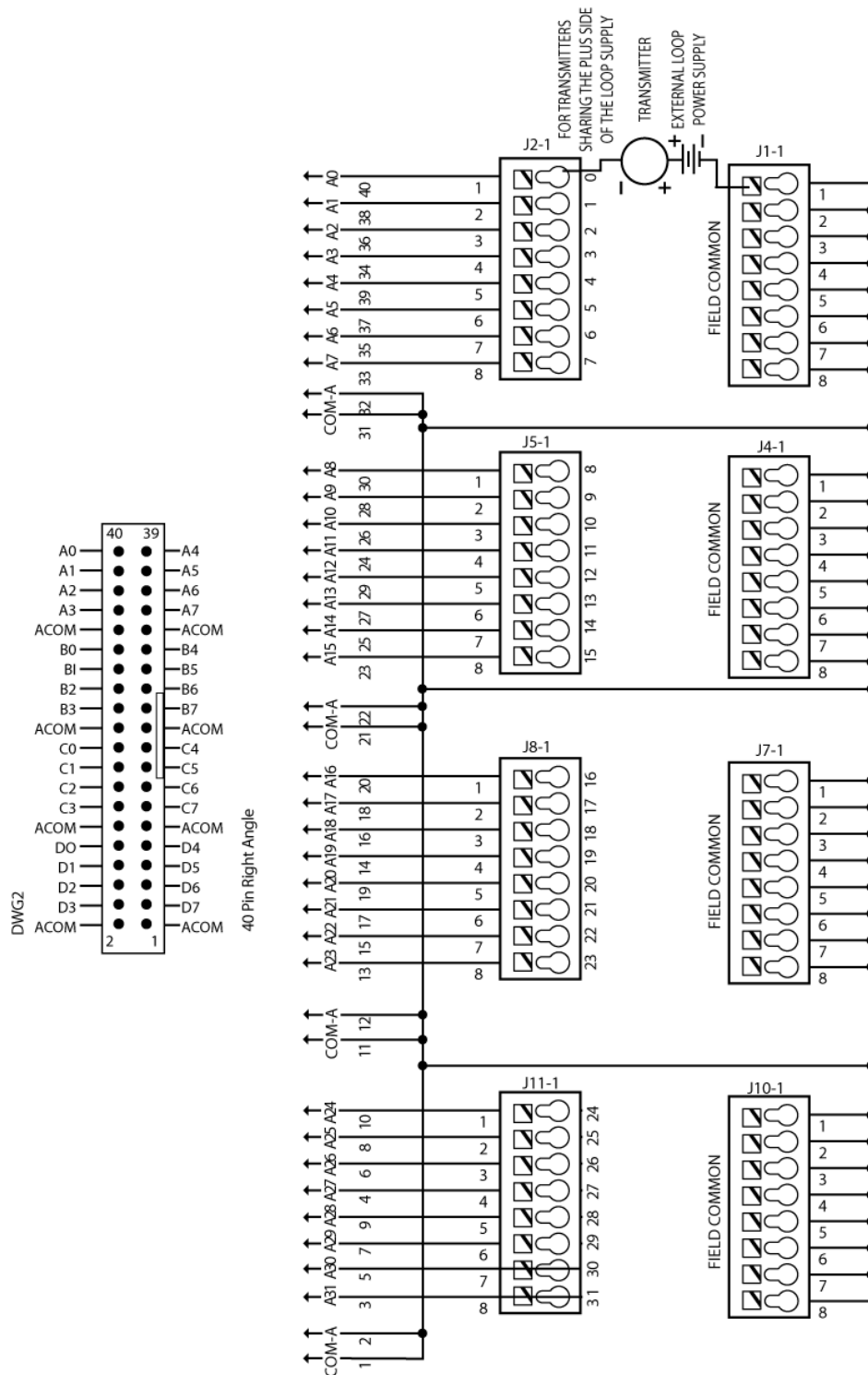

# SNAP Analog Input Modules

## Dimensional Drawing

All Two- and Four-channel Modules, except SNAP-AITM-2

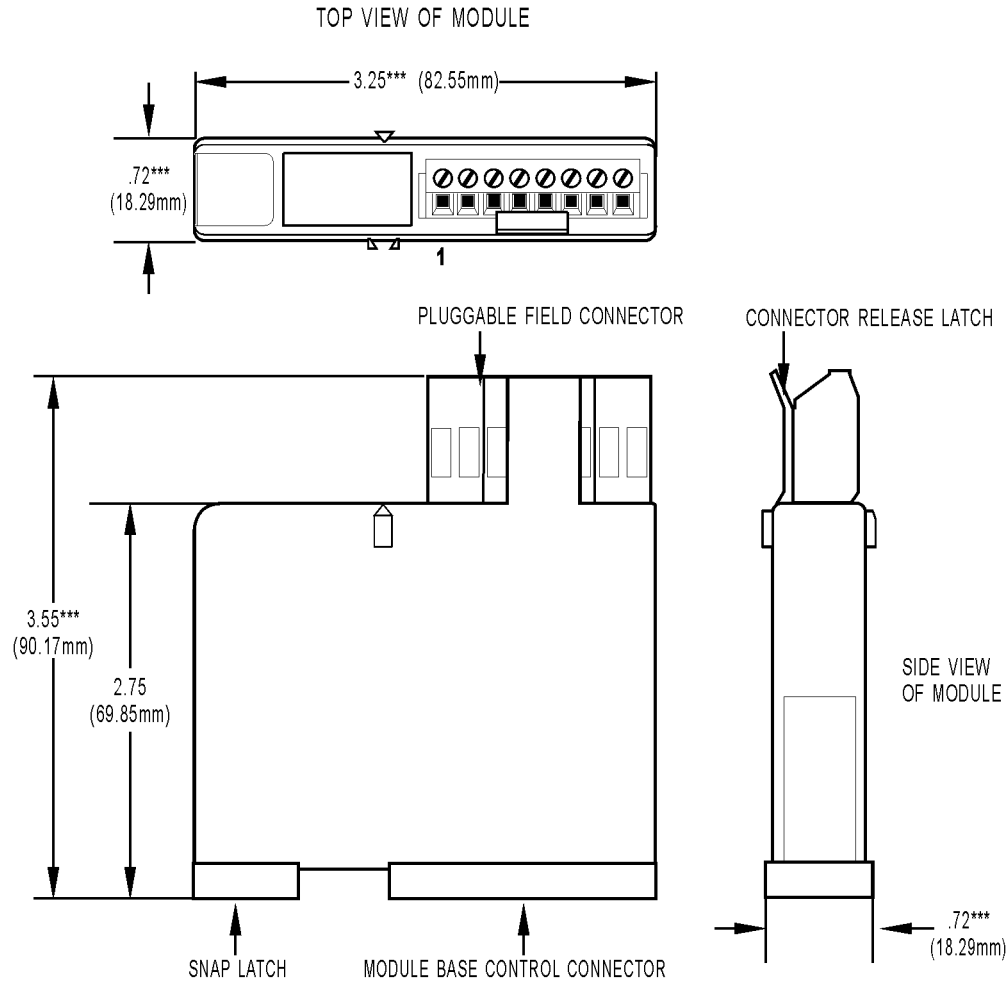

TOLERANCES LEGEND  
 \* +/- .010"      \*\* +/- .020"  
 \*\*\* +/- .030"    \*\*\*\* +/- .060"  
 NO \* REFERENCE ONLY

# SNAP Analog Input Modules

## Dimensional Drawing

### SNAP-AITM-2 Modules

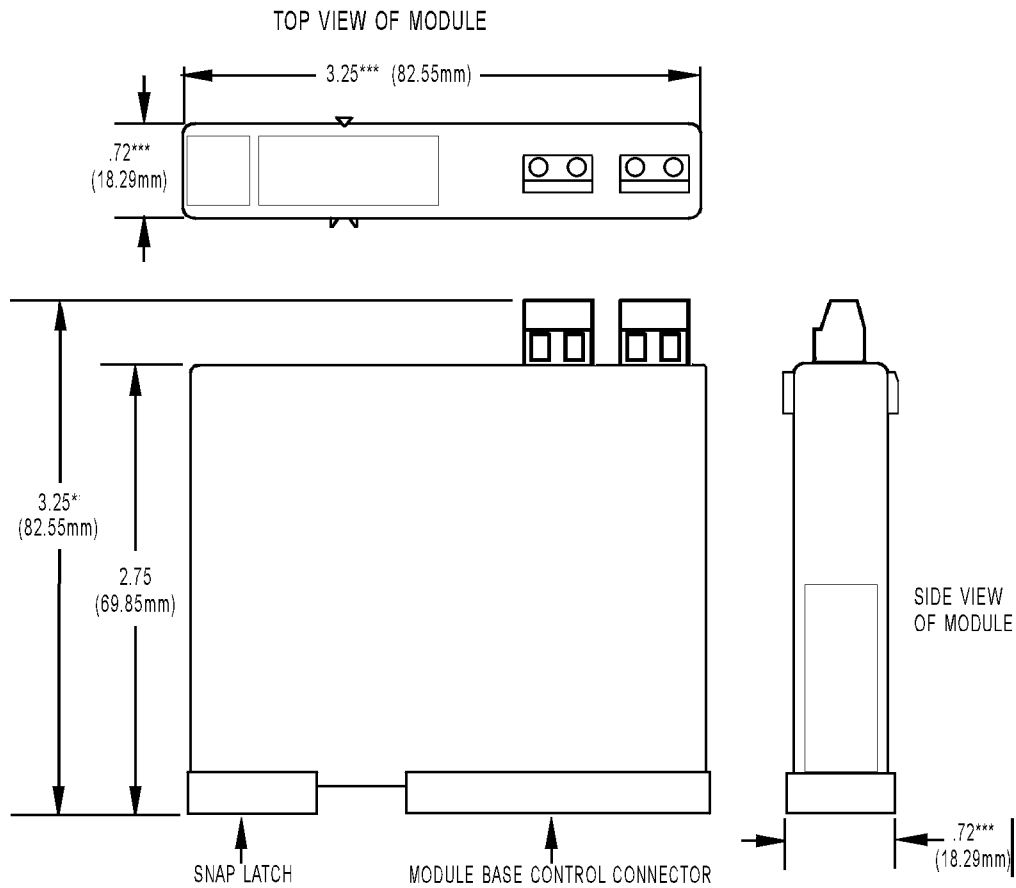

TOLERANCES LEGEND  
 \* +/- .010"      \*\* +/- .020"  
 \*\*\* +/- .030"    \*\*\*\* +/- .060"  
 NO \* REFERENCE ONLY

# SNAP Analog Input Modules

## Dimensional Drawing

SNAP-AITM-8 and SNAP-AITM-8-FM Modules

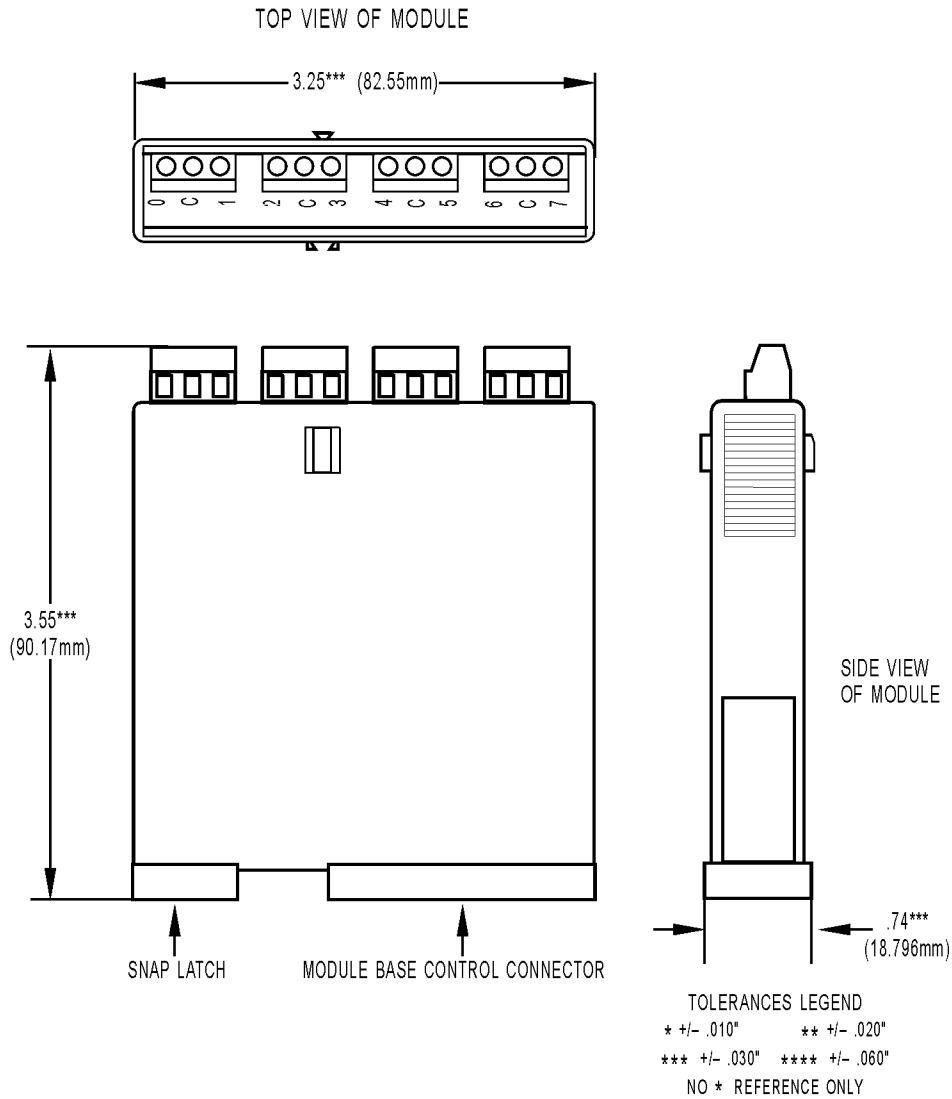



# SNAP Analog Input Modules

## Dimensional Drawing

SNAP-AICTD-8, SNAP-AIMA-8, SNAP-AIV-8, and SNAP-AIR400K-8 Modules

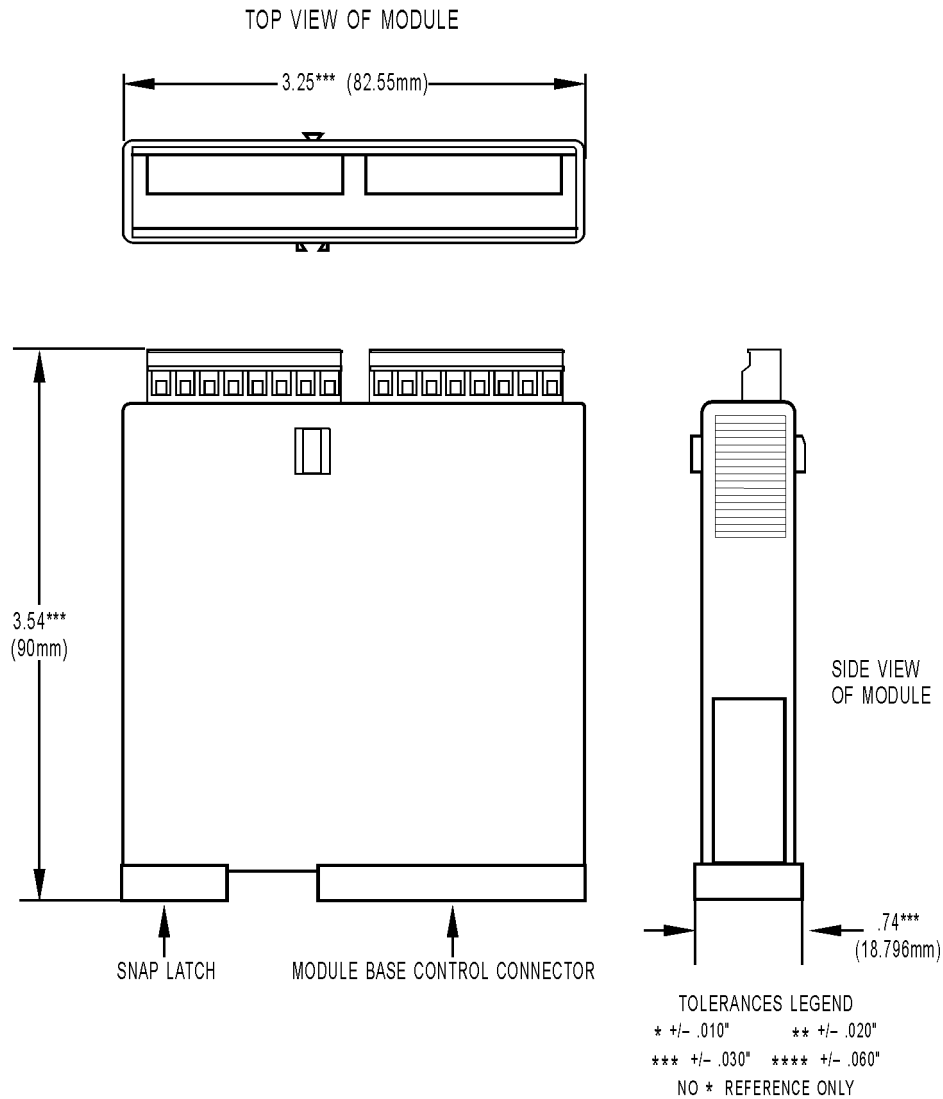

# SNAP Analog Input Modules

## Dimensional Drawing

SNAP-AIRTD-8U

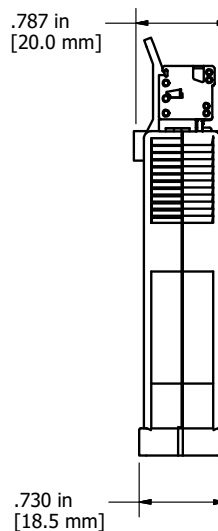
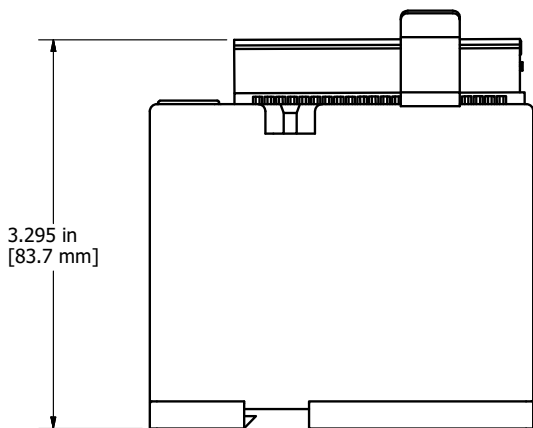
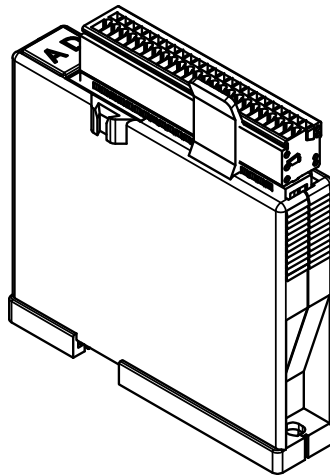
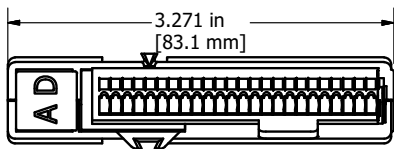

# SNAP Analog Input Modules

## Dimensional Drawing

All 32-Channel Modules

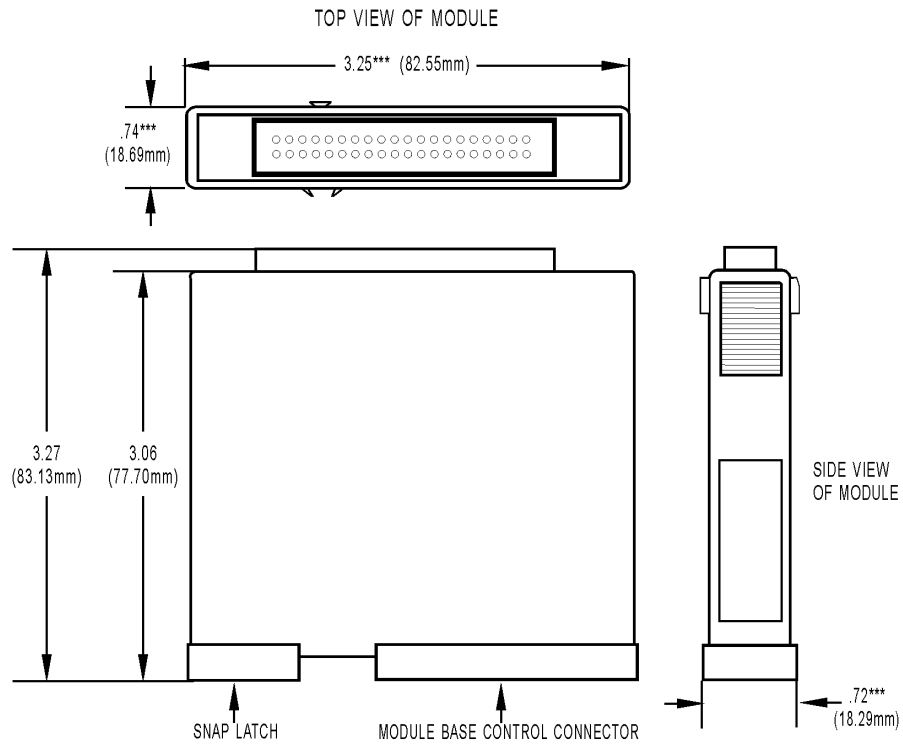

TOLERANCES LEGEND  
 \* +/- .010"      \*\* +/- .020"  
 \*\*\* +/- .030"    \*\*\*\* +/- .060"  
 NO \* REFERENCE ONLY

# SNAP Analog Input Modules

## Dimensional Drawing

All Modules

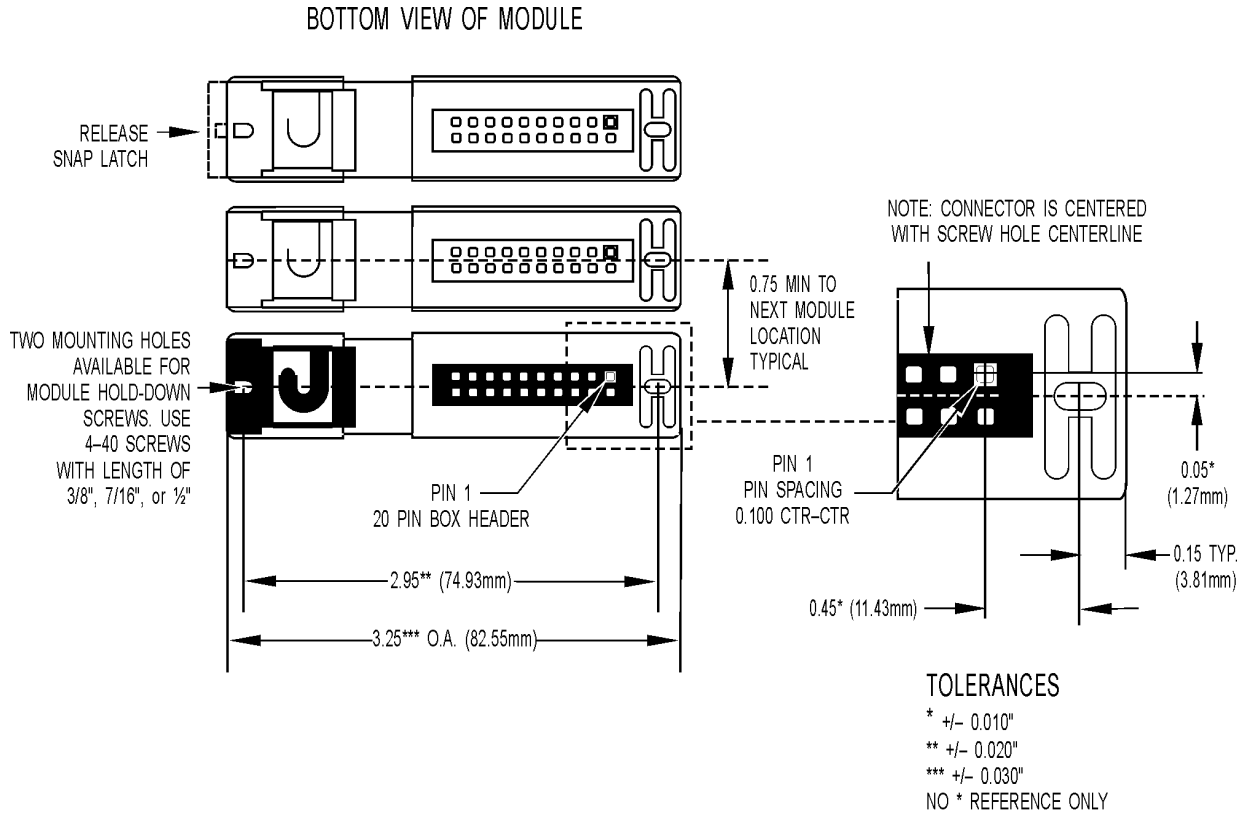

IMPORTANT: The mounting rack connector has 24 pins; the module connector has 20 pins. The extra pins on the mounting rack connector prevent misalignment of the module during installation.

# SNAP Analog Input Modules

## Dimensional Drawing

Height on Rack: All Two- and Four-channel Modules, except SNAP-AITM-2

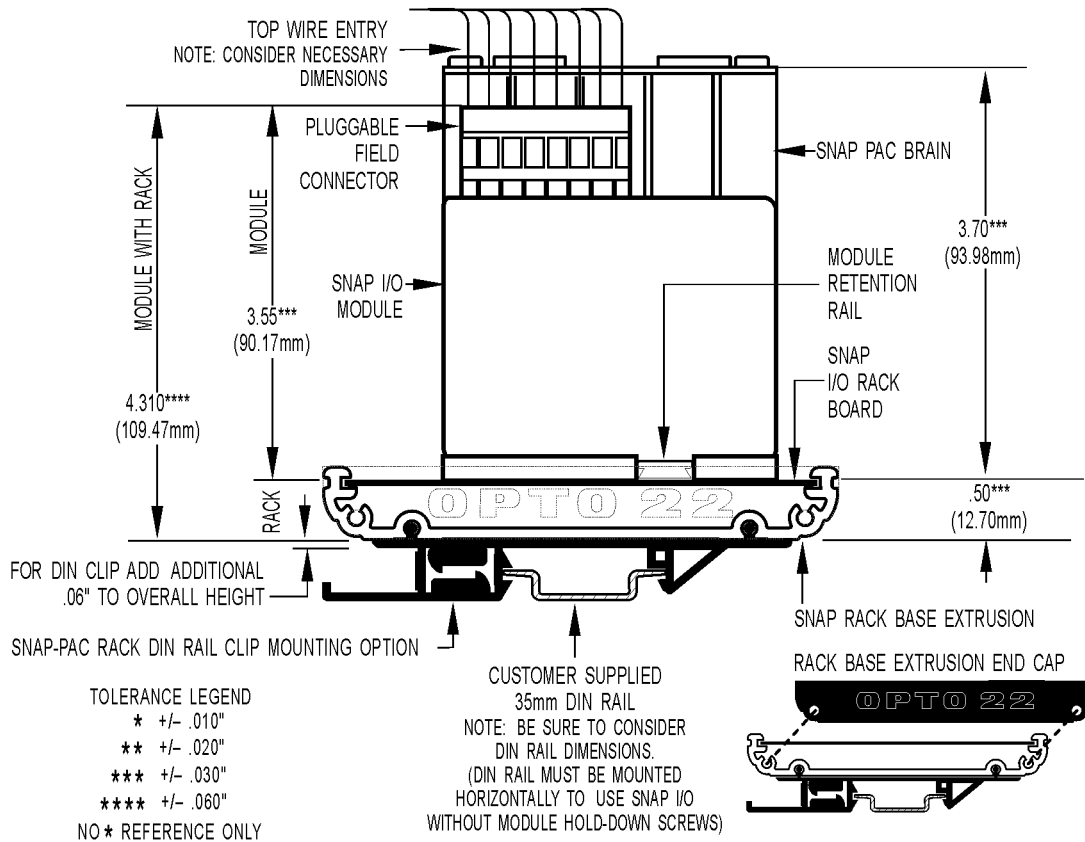

# SNAP Analog Input Modules

## Dimensional Drawing

Height on Rack: 32-Channel Modules

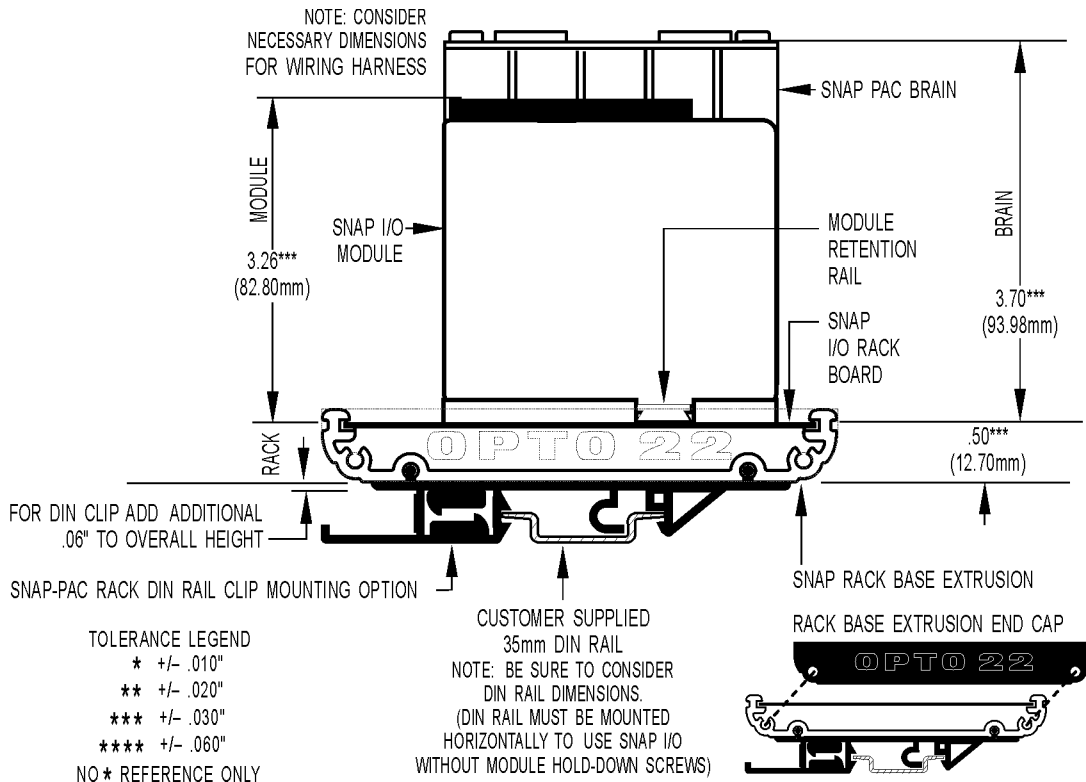

# SNAP Analog Input Modules

## Dimensional Drawing

### Height on Rack: SNAP-AITM-2 Module

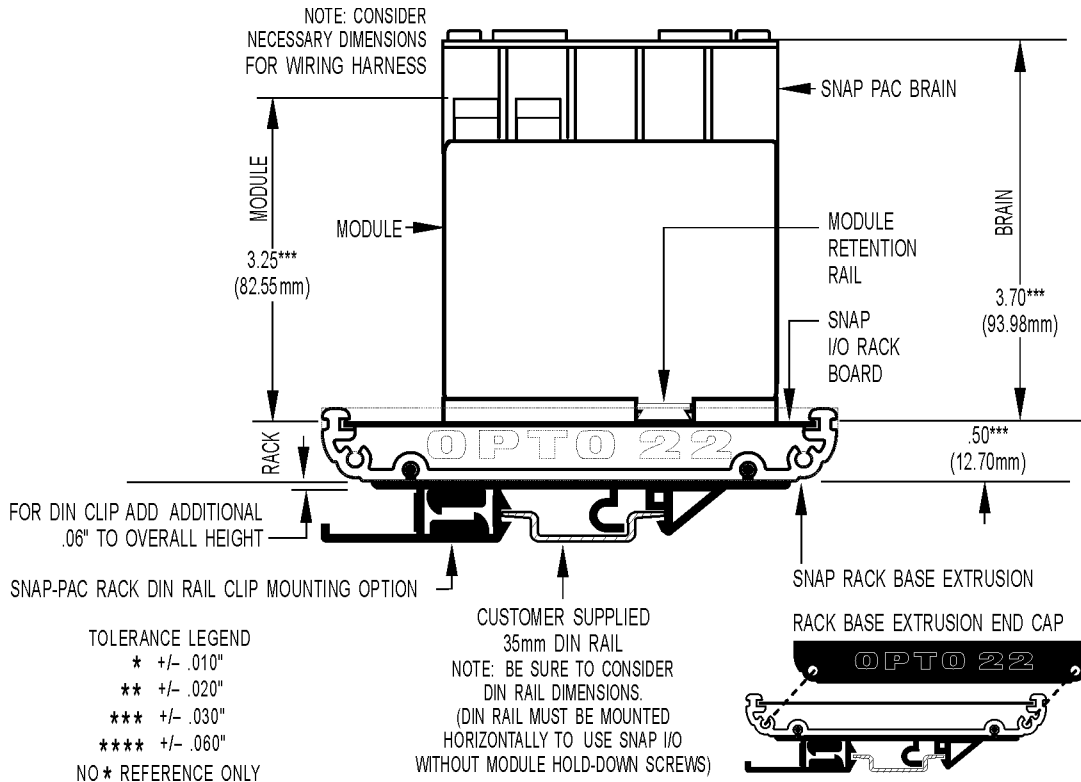



# SNAP Analog Input Modules

## Dimensional Drawing

Height on Rack: SNAP-AITM-8 and SNAP-AITM-8-FM Modules

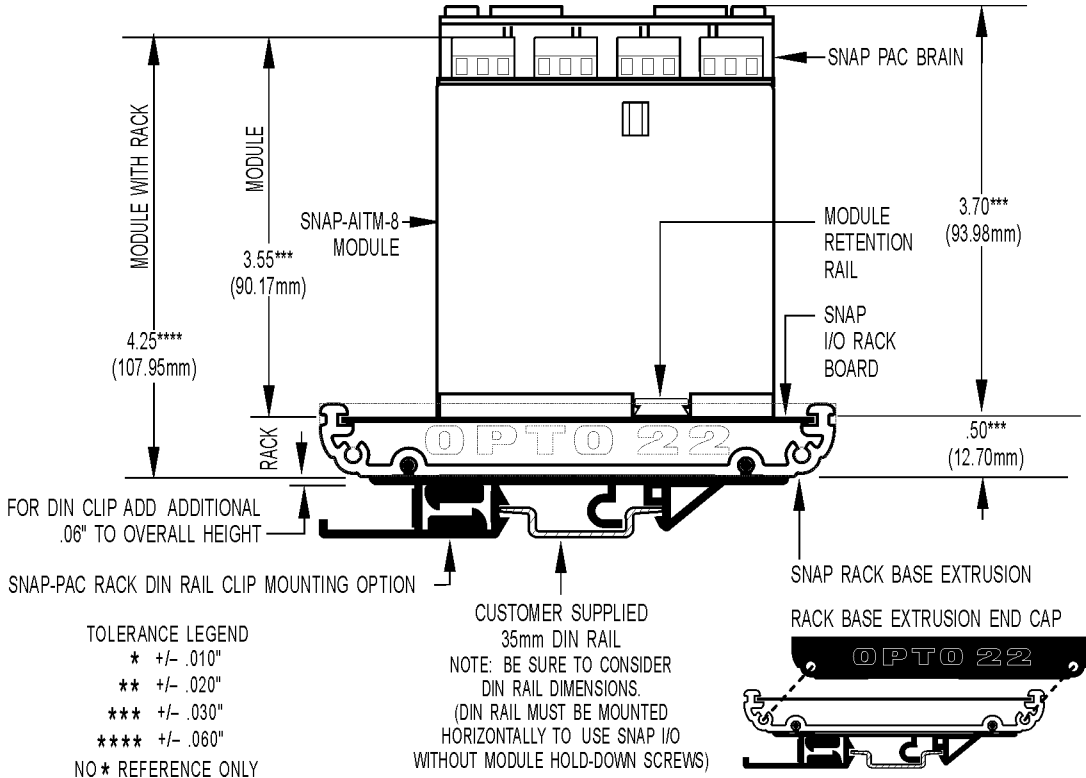

# SNAP Analog Input Modules

## Dimensional Drawing

Height on Rack: SNAP-AICTD-8, SNAP-AIMA-8, and SNAP-AIV-8

